

**⚠ WARNING! READ ⚠
BEFORE INSTALLATION**

1. GENERAL:

A failure resulting in **injury** or **damage** may be caused by excessive overpressure, excessive vibration or pressure pulsation, excessive instrument temperature, corrosion of the pressure containing parts, or other misuse. Consult Ashcroft Inc., Stratford, Connecticut, USA before installing if there are any questions or concerns.

2. OVERPRESSURE:

Pressure spikes in excess of the rated overpressure capability of the transducer may cause **irreversible electrical and/or mechanical damage** to the pressure measuring and containing elements.

Fluid hammer and surges can destroy any pressure transducer and must always be avoided. A pressure snubber should be installed to eliminate the damaging hammer effects. Fluid hammer occurs when a liquid flow is suddenly stopped, as with quick closing solenoid valves. Surges occur when flow is suddenly begun, as when a pump is turned on at full power or a valve is quickly opened.

Liquid surges are particularly damaging to pressure transducers if the pipe is originally empty. To avoid damaging surges, fluid lines should remain full (if possible), pumps should be brought up to power slowly, and valves opened slowly. To avoid damage from both fluid hammer and surges, a surge chamber should be installed.

Symptoms of fluid hammer and surge's damaging effects:

- Pressure transducer exhibits an output at zero pressure (large zero offset).
- Pressure transducer output remains constant regardless of pressure
- In severe cases, there will be no output.

FREEZING:

Prohibit freezing of media in pressure port. Unit should be drained (mount in vertical position with electrical termination upward) to prevent possible overpressure damage from frozen media.

3. STATIC ELECTRICAL CHARGES:

Any electrical device may be susceptible to damage when exposed to static electrical charges. To avoid damage to the transducer observe the following:

- Ground the body of the transducer **BEFORE** making any electrical connections.
- When disconnecting, remove the ground **LAST!**

Note: The shield and drain wire in the cable (if supplied) is not connected to the transducer body, and is not a suitable ground.

Mounting

The KM15 transducer requires no special mounting hardware, and can be mounted in any plane with negligible position error.

Although the unit can withstand normal vibration without damage or significant output effects, it is always good practice to mount the transducer where there is minimum vibration.

For units with NPT type pressure fittings apply Teflon® tape or an equivalent sealant to the threads before installing.

When tightening, apply a wrench to the hex wrench flats located just above the pressure fitting. **DO NOT** tighten by using a pipe wrench on the housing.

Noise

For minimum noise susceptibility, avoid running the transducer's cable in a conduit that contains high current AC power cables. Where possible avoid running the cable near inductive equipment.

Shield Wiring

(Cable Termination Only)

Connect the braided shield to the guard terminal on the reading instrument (meter, etc.) if available or to ground or to the power supply negative terminal.

Vent Tube (Cable Termination Only)

The cable will have a clear Teflon® vent tube that's required at pressure below 500 psi to provide atmospheric reference. The open end should be placed in a dry area.

Output Type	Excitation	Supply Current
0.5/4.5 V Ratiometric	5V±.5 Vdc	10mA typ
1/5V	8-32 Vdc	10mA typ

Teflon is a registered trademark of E. I. DuPont
RoHS Compliant

KM15 PRESSURE TRANSDUCER INSTRUCTION SHEET



METRI-PACK Dimension Drawing

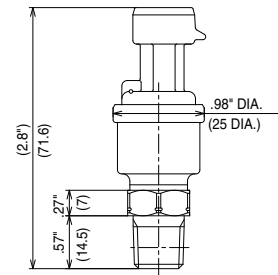
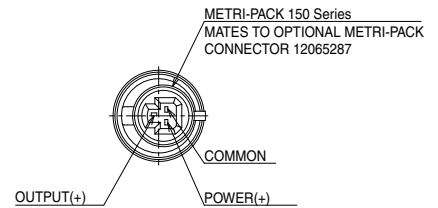
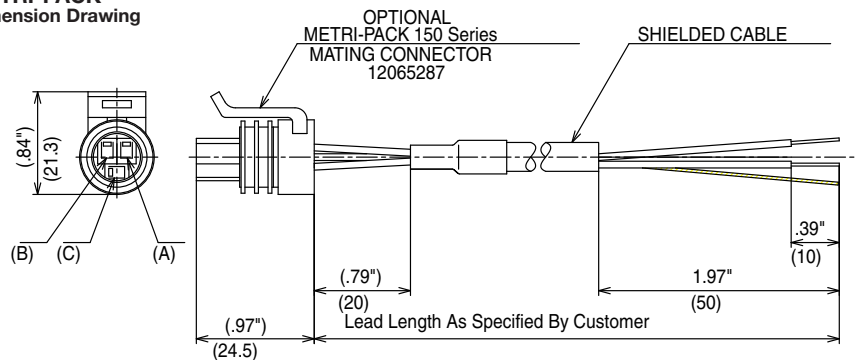

- PIN
(B) -- Red --- Power(+)
(A) -- Black --- Common
(C) -- White --- OutPut(+)

Dimensions in () are mm

FLYING LEAD STYLE Dimension Drawing

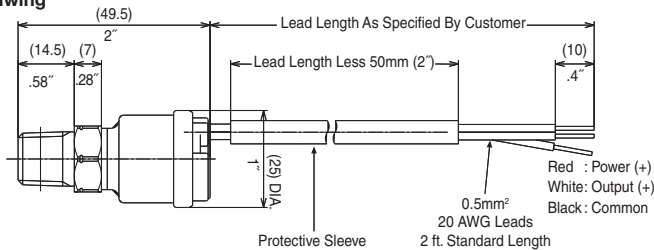

Dimensions in () are mm

CONNECTOR STYLE TERMINATION

Dimension Drawing
(Height may vary slightly depending on process connection)

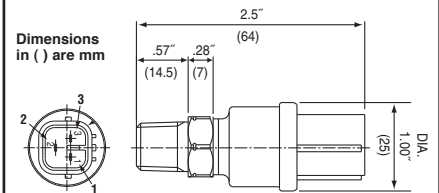

Mating Connector
Mates to HW090 Connector by Sumitomo Wiring Systems. Made of PBT (polybutylene terephthalate).

Flying Leads : 20AWG, 3 ft. (.9m) standard

PIN	Color	Function
1	Red	Supply (+)
2	White	Output (+)
3	Black	Common

SHIELDED CABLE TERMINATION

Dimension Drawing
(Height may vary slightly depending on process connection)

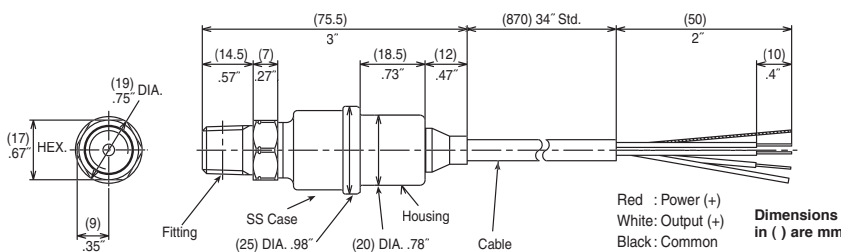

Dimensions in () are mm

WIRING DIAGRAM FOR ALL KM15 TRANSDUCERS

