

Mixed Gas Dispense MGD2

Operating Manual for Installer (all blends)



domnick hunter
Gas Generation Division

domnick hunter ltd Gas Generation Division Dukesway Team Valley Trading Estate Gateshead Tyne and Wear
England NE11 0PZ

Tel: +44 (0)191 402 9000 Fax: +44 (0)191 497 1216

E mail: gasgen@domnickh.co.uk

Section 1 - Using the Operating Manual

This manual contains the information necessary for the correct use of the MGD2 unit.



Warning: Ensure that all personnel involved in the installation, operation and maintenance of the MGD2 unit, as well as those persons who will act as supervisory personnel, have read and fully understood the instructions before attempting to install, operate or perform maintenance on this MGD2 unit.

Should any questions arise regarding safe and proper installation, operation or maintenance of the MGD2 unit, contact **Supplier** before proceeding.

Section 2 - Contents of the Operating Manual

Section 1	Using the Operating Manual
Section 2	Contents of the Operating Manual
Section 3	Symbol Conventions
Section 4	Safety Warning
Section 5	General Information
Section 6	Technical Specifications
Section 7	Emergency Procedure in the Event of a Loss in Ringmain Pressure
Section 8	Ringmain Leaks
Section 9	Unpacking the Generator
Section 10	Installing and Operation of the Generator
Section 11	Maintenance
Section 12	Troubleshooting
Section 13	P & I Diagram/Electrical Wiring Diagram

Section 3 - Symbol Conventions



WARNING: The WARNING symbol draws attention to an operating procedure or practice that can cause injury if it is not correctly performed or observed. Do not continue past a WARNING symbol until you have fully understood or satisfied the indicated conditions.



CAUTION: The CAUTION symbol draws attention to an operating procedure or practice that can partially or completely damage the unit if it is not correctly performed or observed. Do not continue past a CAUTION symbol until you have completely understood or satisfied the indicated conditions.



NOTE: The NOTE symbol draws attention to information that is especially important to an operating procedure or a practice that is advisable to perform correctly or observe, but that cannot partially or completely damage the unit.

Section 4 - Safety Warning



Do not operate the MGD2 unit until the information contained in this document has been read and understood by all personnel concerned.

Nitrogen & CO₂ are not poisonous gases but, in a concentrated form, there is a risk of asphyxiation. The MGD2 unit produces a small flow of mixed gases, which quickly disperse in the atmosphere. However, do not directly inhale any gases produced by the MGD2 unit.

Before servicing or maintenance is performed on the MGD2 unit, electrical supplies must be switched off.

All personnel handling, using or maintaining this MGD2 unit must employ safe working practices and observe all relevant local health and safety regulations.



The unit should be connected to a suitable electrical mains supply in accordance with local safety regulations. Ensure the rating plate corresponds to the supply voltage. ***Ensure the unit is earthed.***

Section 5 - General Information

- 5.1) The MGD2 unit is designed to produce two different mixtures of carbon dioxide (CO₂) and nitrogen (N₂) simultaneously (dependant on the model) at pre-determined ratios.

30:50 blend		30:60 blend	
30% CO ₂	50% CO ₂	30% CO ₂	60% CO ₂
70% N ₂	50% N ₂	70% N ₂	40% N ₂

Connections are also provided for pure N₂

Schematic A

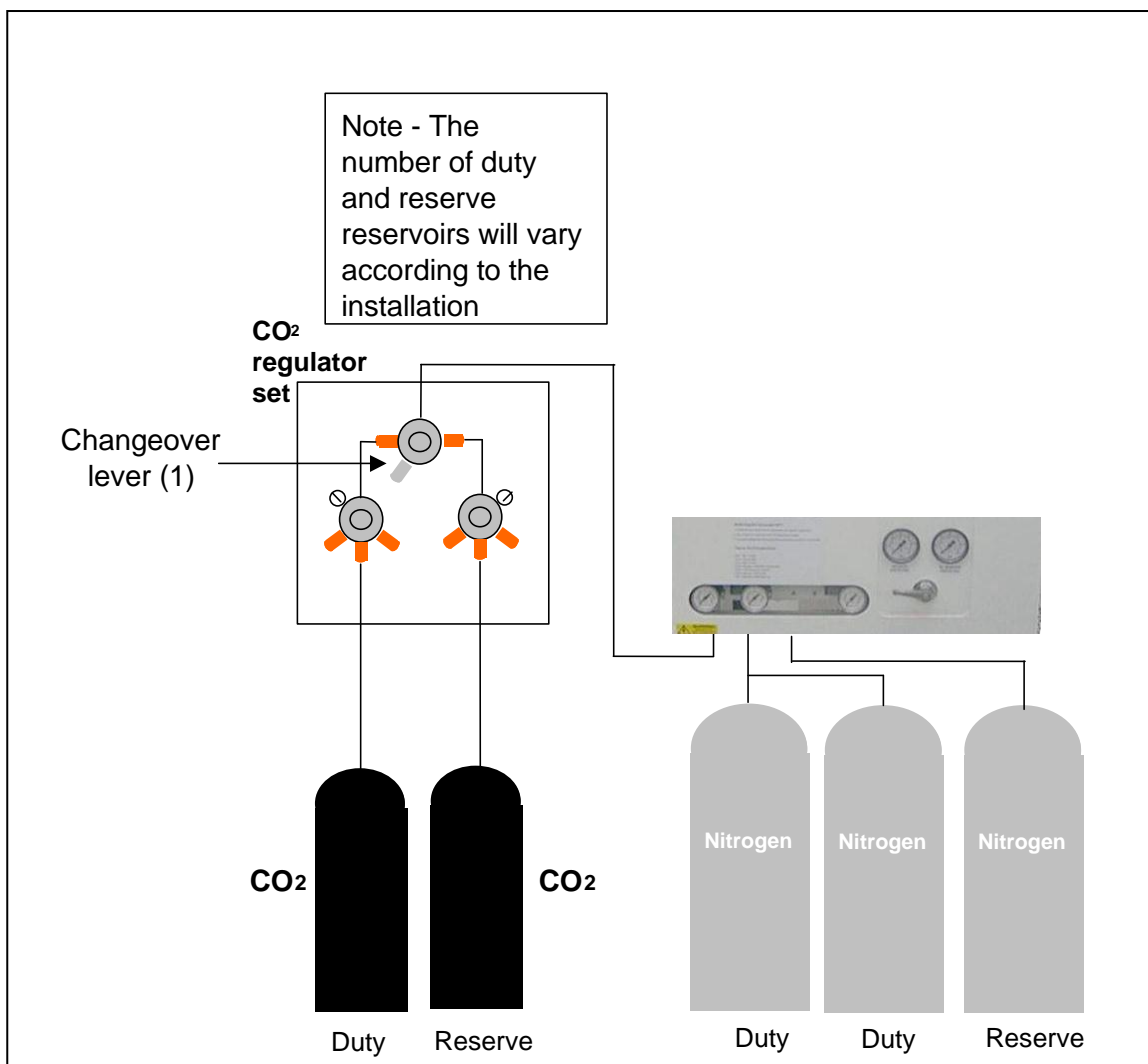

Stock No: 17 626 0708 Rev 03

Schematic B

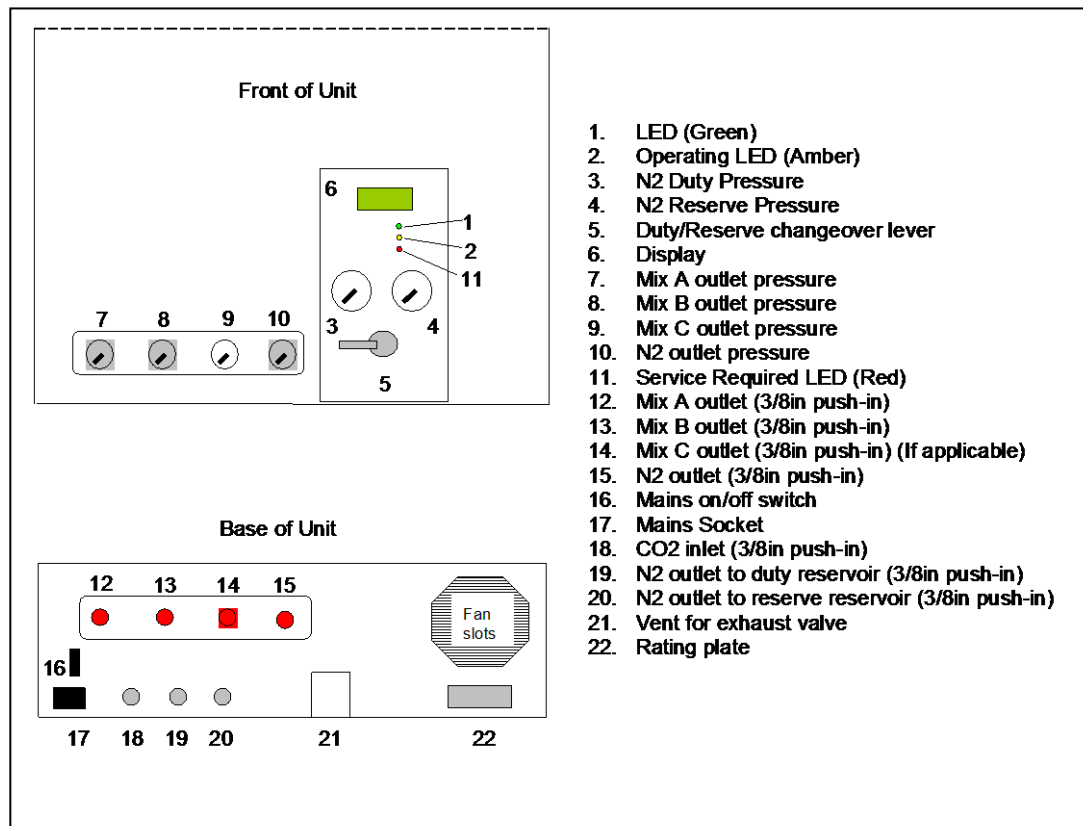

- 5.2) The CO₂ is supplied from cylinders and the N₂ is produced by separating N₂ from the atmosphere using a Carbon Molecular Sieve (CMS). **The unit will depressurise every two minutes (approx), resulting in an audible pulse of gas, which is normal.**
- 5.3) The MGD2 unit is classified as non-hazardous for transportation purposes and non-flammable for fire regulations.



Any fire should be fought by means appropriate to the material causing the fire with the exception being the use of water. Disposal of the unit should be at a licensed landfill site.



Any interference with the calibration warning labels will invalidate the MGD2 unit warranty and may incur costs for re-calibration.

Section 6 - Technical Specifications

- **Models:** MGD2
- **Dimensions:** Height = 887mm
Width = 533mm
Depth = 257mm
- **Total Weight** Approx 50kg
- **Cabinet Materials** Mild steel, phosphated coated, painted traffic white
- **Flow Rate:** 5 litres/minute of N₂
- **Nitrogen Purity:** >99.8% (<0.2% oxygen)
- **Electrical Mains Supply:** 230Vac 50/60Hz & 115 Vac 60 Hz
- **External Fuse Rating:** 5A 230Vac only
- **External Gas Requirement:** CO₂ @ 5.5 to 6barg (80 to 87psig)
- **Ambient Temperature:** +2 to + 35°C
- **Outlet Pressure:** Normal running = 8barg (116psig)
- **Max N₂ Storage Pressure:** 9.5barg (138psig)
- **Mixed Blends:** Dependent on model
- **Inlet and Outlet Port Size:** 3/8in push-in fittings

Section 7 – Emergency Procedure in the Event of a Loss in Ringmain Pressure





- Check the pressure on the CO₂ cylinder panel shown on the CO₂ regulator set. If pressure shown on the CO₂ regulator set is low, then switch the changeover lever (1 on Schematic A) to bring the reserve cylinder into service. Exchange the empty cylinder.
- Check the on/off switch (on the base of the MGD2 unit) is ON (15 on Schematic B), and ensure the green LED (1 on Schematic B) is illuminated.
- Check the pressure in the duty nitrogen (N₂) reservoirs is above 5.5barg (80psig). If the pressure is below this figure, switch over the changeover lever (5 on Schematic B) to the reserve reservoir and call Supplier.

Section 8 – Ringmain Leaks

- 8.1) If the loss of pressure is due to a leakage or rupture of a pipeline, take the following actions:
- Do not enter the area of leakage until it is safe to do so (refer to supplier safety and data sheets)
 - Ensure the area is well ventilated before entering
 - Turn off all cylinders
 - Switch off the MGD2 unit
 - If the leakage is from supplier equipment call supplier. If the leakage is from the ringmain, contact Brewery Technical Services
 - Contact your supplier service centre for advice

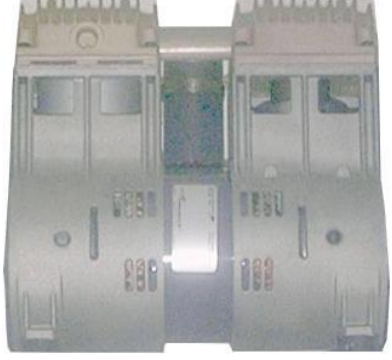
Section 9 - Unpacking the Generator

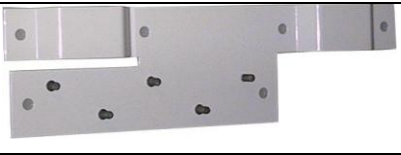
9.1) The packing box will contain the following items:

<p>Compressor (in a cardboard box)</p>	
<p>Compressor plate</p>	
<p>Backplate</p>	
<p>MGD2 unit</p>	

Remove the items from the box and visually check for damage. If any of the items are in a damaged condition, request an immediate inspection by the carrier.

Section 10 - Installation and Operation of the Generator

The MGD2 unit is mounted in stages to minimise the maximum weight lifted during the wall mounting procedure.

- | | |
|---------|--|
| Stage 1 | Mounting the Backplate onto the Wall |
| Stage 2 | Hooking the MGD2 Unit onto the Backplate |
| Stage 3 | Installing the Compressor and Electrical Power Up |
| Stage 4 | Installation of External Isolation Valves, CO2 Line, Mixed Blend Lines, Duty and Reserve Tanks |
| Stage 5 | Installing the Front Cover |

10.1) Stage 1 – Mounting the Backplate onto the Wall

Using a spirit level, mark a line at the point at which the MGD2 unit will be secured to the wall. Ensure the condition of the wall is suitable for mounting the MGD2 unit.



Ensure that there are no electrical devices below the MGD2 unit, as condensate (water) may drip from the MGD2 unit dependent on ambient humidity.



The use of noxious chemicals or machinery that produces fumes is not permitted within a 5 metre radius of the MGD2 unit.

Mark the position for the six fixing bolts (on the backplate) and drill using M16 drill. It is recommended that the mounting bracket is secured using Rawlbolts (M10 thread, shank diameter = 16mm, total length = 70mm).

Securely bolt the backplate to the wall.



Stock No: 17 626 0708 Rev 03



The fixing method utilised must be suitable for the type of wall construction, and must be capable of supporting the full weight of the MGD2 unit. If in doubt, consult a qualified builder. Approx weight = 50kg.

ENSURE SAFETY GOGGLES ARE USED.

10.2) Stage 2 – Hooking the MGD2 Unit onto the Backplate.

- Remove the bubble wrap from the MGD2 unit and unscrew the M5 screws from the front cover.
- Remove the front cover, ensuring that the flying earth lead is disconnected
 - Locate the MGD2 unit on the backplate via the two pegs on the back of the unit
 - Note: The photo shows the unit hooking on from the reverse angle

10.3) Stage 3 – Installation of Compressor/Electrical Power Up

- Bolt the compressor plate to
- the backplate using the M8
- nuts supplied.

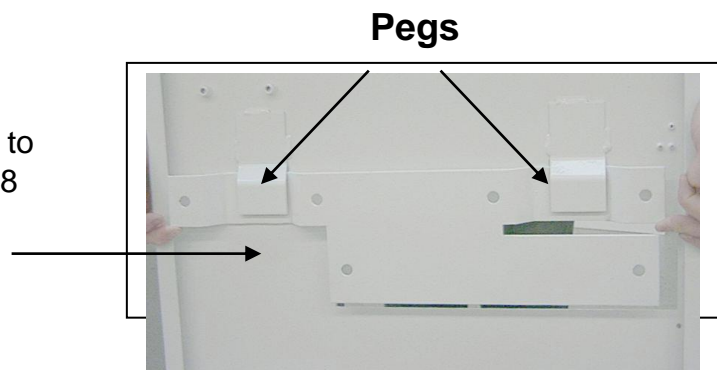

- Place the compressor with its anti-vibration mounts onto the mounting plate and secure using the nuts supplied.



- Connect the white PTFE tube
- to brass union connector,
- using a 13mm spanner.

DO NOT USE PTFE TAPE, WHICH MAY DAMAGE THE COMPRESSOR

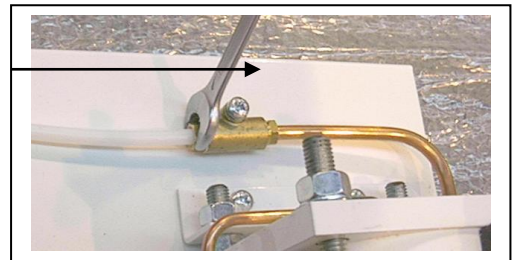

- Connect the air intake filter/tube to the
- elbow fitting on the compressor.

DO NOT USE PTFE TAPE, WHICH MAY DAMAGE THE COMPRESSOR

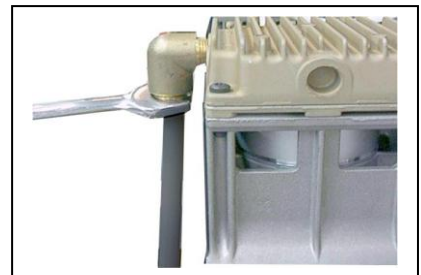

The unit should be connected to a suitable electrical mains supply in accordance with local safety regulations. Ensure the rating plate corresponds to the supply voltage. ***Ensure the unit is earthed.***

- Take the 3 pin plug at the end of the compressor wires and connect it into the panel mounted socket. Once connected, secure the screw supplied to prevent the plug from vibrating loose.

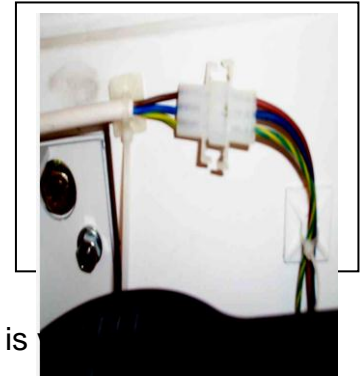

Once the MGD2 unit is installed, the operation procedure is

- Connect the MGD2 unit to an approved 240 Vac single phase 3 pin socket protected by a circuit breaker (RCD)
- Switch the MGD2 unit on via the On/Off mains switch (15), and ensure the green LED is illuminated. The amber LED may illuminate if the pressure in the system is less than 9.5barg (138psig)
- Ensure the electrical power is not switched off

10.4) Stage 4 - Install External Isolation Valves, CO₂, Mixed Blend Lines, Duty and Reserve Tanks



Ensure that only approved CO₂ cylinders are connected to the regulator set (Schematic A).

- Connect the CO₂ line to the MGD2 unit
- Connect the duty and reserve cylinders
- Connect the mixed blend lines (Mix A and Mix B)
- Close valves V1, V2, V3, V4 and V5

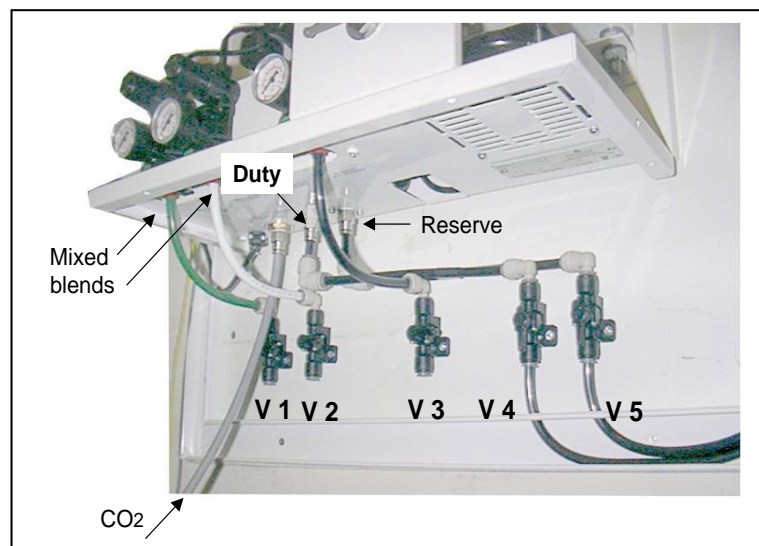

- Open red valves on PCMs
- Adjust regulators to regulate pressure as per brewer's specifications
- Leak check all fittings whilst observing pressure gauges. This will confirm leak tightness of the MGD2 unit as well as indicate the position of any external leaks

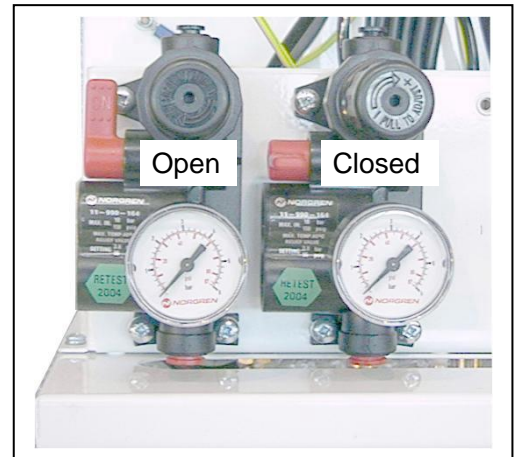

10.5) Stage 5 – Installing the Front Cover

- Switch off MGD2 unit
- Connect the flying earth lead from the MGD2 unit to the front cover
- Locate the lip at the top of the front cover and hook this onto the top of the MGD2 unit
- Gently ease the front cover onto the main frame. Secure using the screws supplied
- Switch on the MGD2 unit

Section 11 - Maintenance

To maintain the quality and reliability of the MGD2 unit, the following preventative maintenance should be carried out.











Keep a written record of all maintenance undertaken. Failure to undertake the specified service may cause damage to the MGD2 unit.

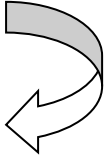

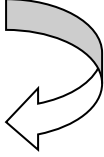
Order any replacement parts before you require the maintenance to take place. Use only genuine **DH or its subcontractor** parts as supplied by **DH or its subcontractor**.

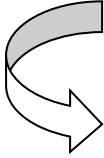
11.1) Shutdown Procedure

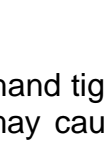

Before carrying out the maintenance, turn the MGD2 unit off by disconnecting the mains power supply. (Note: the green 'mains' light extinguishes).

Procedure for Replacing Coalescing Filter/Solenoid Valve/Silencer Replacement		
	Switch off the electrical power supply to the MGD2 unit. Depressurise the system.	
	Disconnect solenoid valve from filter housing by unscrewing the tube nut.	
	Unscrew the housing bowl (anti-clockwise). 	
	Unscrew the filter (anti-clockwise) and discard. 	
	Fit the replacement filter by screwing it in clockwise until hand tight. 	
	Replace the housing bowl (clockwise) until hand tight. Do not use a wrench or other tools that may cause damage to the bowl. 	

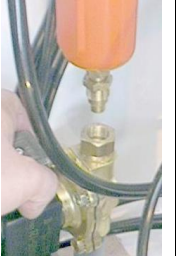
	Remove the electrical plug from the valve using a Terminal screwdriver.	
	Disconnect the adjoining pipework.	
	Remove the silencer and any fittings adjoining the valve noting their orientation. The solenoid valve should then be discarded.	
	Replace the blue plastic silencer and brass sintered silencer.	
	Replace the solenoid valve and return the new silencer and any fittings in the same orientation as the old valve. Pipe thread sealant is recommended.	
	Reconnect the pipework to the solenoid valve (using suitable pipe thread sealant).	
	Reconnect the electrical connections using a Terminal screwdriver.	
	Reconnect the solenoid valve assembly to the filter housing.	

Section 12 - Troubleshooting

Fault Found	Probable Cause	Remedy	Comments
No power. LEDs not illuminated	Incorrect input voltage	Check mains voltage and rating number plate for voltage spec	
	External fuse blown	Check fuse, replace if necessary.	
	Internal fuse blown	Contact Brewery Technical Services	
	On/Off switch failure	Check and replace	
	Faulty LED	Check and replace	
LEDs illuminated but no operation	Internal fuse blown	Contact Brewery Technical Services	
Low or no flow	Internal leak	Check for leaks and CO2 gas levels	
	Exhaust solenoid valve permanently venting	Check and replace	
	Faulty pressure regulator	Check and replace	

Section 13 - P & I Diagram/Electrical Wiring Diagram

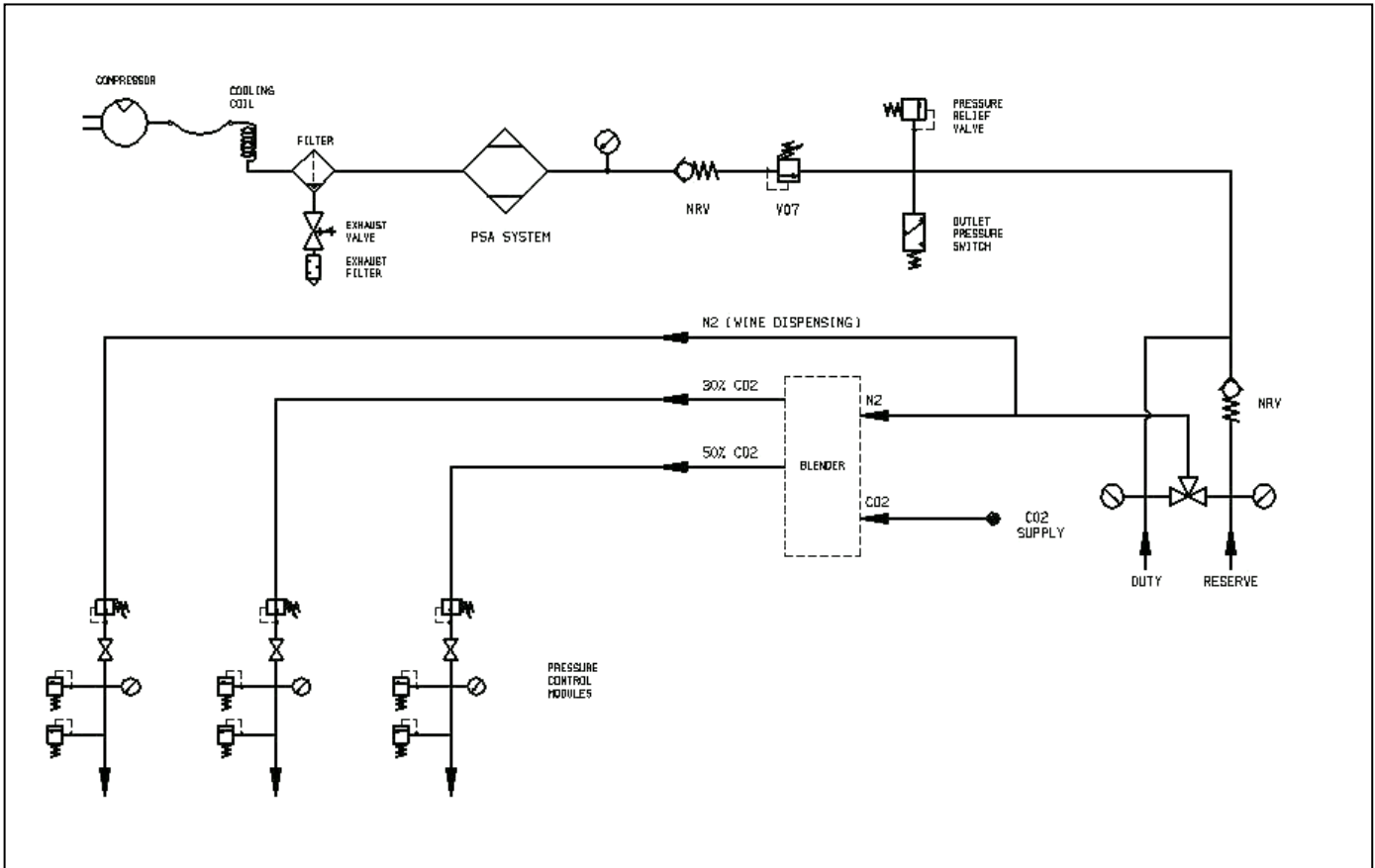

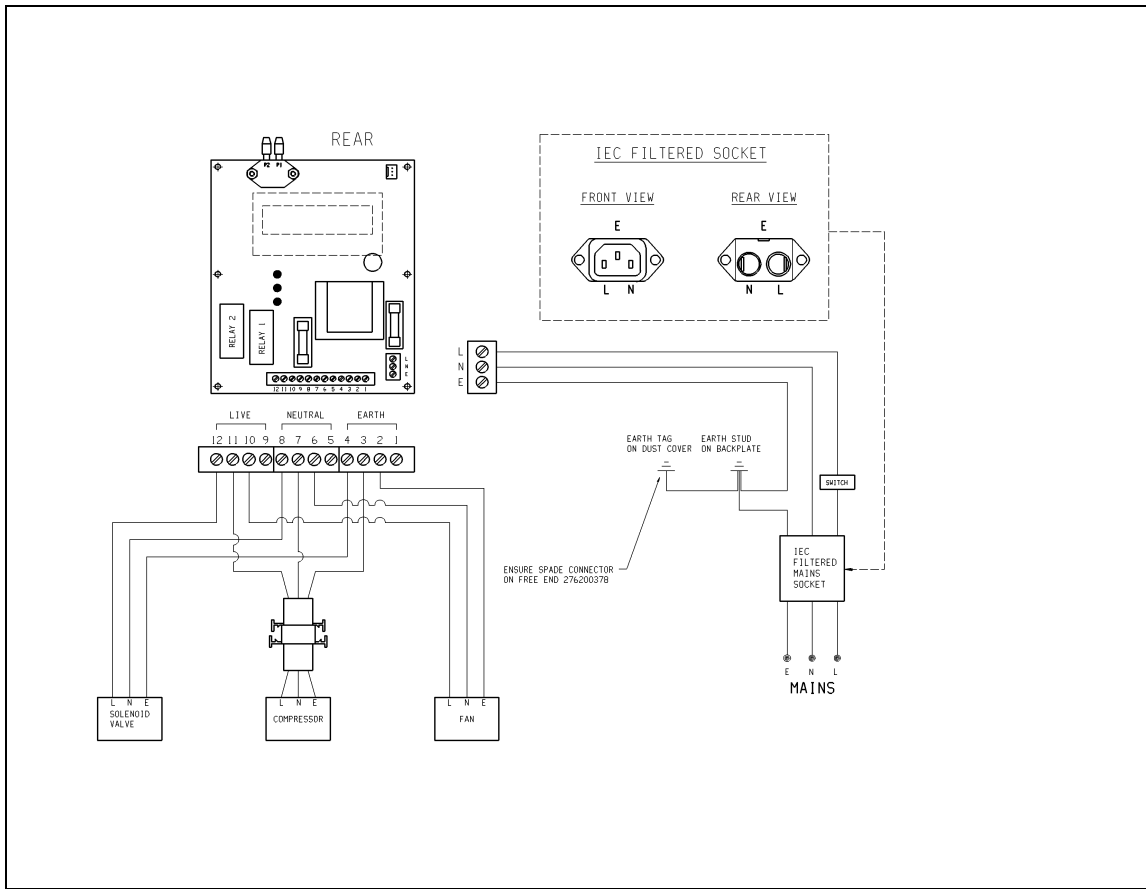

**DECLARATION OF CONFORMITY FOR Gas Gen. Mk5
73/23/EEC 98/37/EC 89/336/EEC 97/23/EC**

Name of manufacturer or supplier:
domnick hunter ltd.

Full postal address including country of origin:
**Dukesway, TVTE, Gateshead, Tyne & Wear, NE11 0PZ
United Kingdom**

Place of issue: **Gateshead**

Description of product: **Gas Gen. Mixed Gas Dispense Unit.**

Name, type or model, batch or serial number
MGD2

Directives used

73/23/EEC 98/37/EC 89/336/EEC 97/23/EC

Standards used, including number, title, issue date and related documents

**Generally In accordance with ASMEVIII div.1 : 1995 upto and including 1996 addenda
EN292-1: 1991 & EN292-2: 1991, EN50081-2: 1994, EN50081-1: 1992, EN50082-1: 1998 &
EN50082-2: 1995, EN61010-1: 1993.**

Notified body for PED Regulations: Lloyds Register of Shipping 71 Fenchurch St. London EC3M 4BS	Conformity Assessment Route: A
EC Type Examination Certificate: BHM014001/New 5" Column/TEC	Harmonised Standards: None

Name of authorised representative
Barry Wade

Position of authorised representative
Business Systems Improvement Manager

Full postal address if different from above
AS ABOVE

Declaration

I declare that as the authorised representative, the above information in relation to the supply / manufacture of this product, is in conformity with the standards and other documents following the provisions of the above Directives.

Signature of authorised representative



Stock No: 17 626 0708 Rev 03



dh and domnick hunter are registered trademarks of Parker Hannifin Ltd.
domnick hunter has a continuous policy of product development and although the Company reserves the right to change specifications, it attempts to keep customers informed of any alterations. This publication is for general information only and customers are requested to contact your domnick hunter sales representative for detailed information and advice on a products suitability for specific applications. All products are sold subject to the Company's standard conditions of sale.

Copyright Parker Hannifin 2007

Stock No. 17 626 0708 Rev_003



A division of Parker Hannifin Corporation



domnick hunter

Parker Hannifin Ltd
Dukesway, Team Valley Trading Estate
Gateshead, Tyne and Wear
England NE11 0PZ
Tel: +44 (0)191 402 9000
Fax: +44 (0)191 482 6296
www.domnickhunter.com