

Level measurement

Continuous level measurement
Accessories for level sensors

TS-3 temperature sensor

Overview

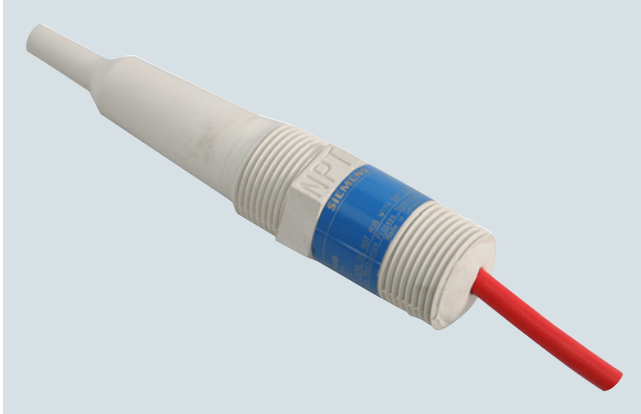

The TS-3 temperature sensor provides an input signal for temperature compensation of specific Siemens ultrasonic level controllers.

Benefits

- Chemically resistant ETFE enclosure
- Fast response time
- Approved for use in potentially explosive atmospheres

Application

Temperature compensation is essential in applications where temperature variations of the sound medium are expected.

By installing the temperature sensor close to the sound path of the associated ultrasonic transducer, a signal representative of the sound medium's ambient temperature is obtained. The temperature sensor should not be mounted in direct sunlight.

The TS-3 is used in conjunction with ultrasonic transducers that do not have an integral temperature sensor. It is also recommended in cases where the integral temperature sensor of the transducer cannot be used.

The following conditions are typical for use of the TS-3 sensor: where a fast reaction to temperature variations is required, where a flanged ultrasonic transducer is used, or where high temperatures are encountered.

The TS-3 is not compatible with devices using the TS-2 or LTS-1 temperature sensors. Refer to the associated controller manual for more details.

- Key Applications: for use in applications where temperature sensor measurement from transducer does not accurately represent vessel temperature. Used for applications requiring quick temperature response (open channel monitoring).

Design

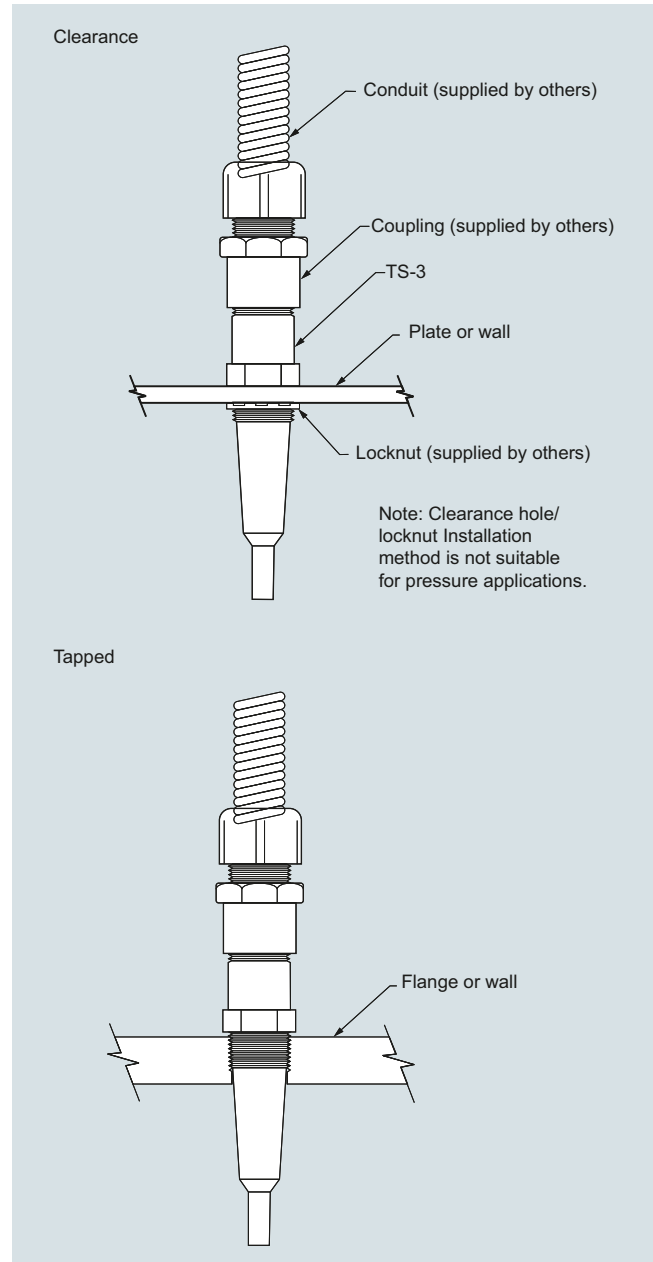

TS-3 temperature sensor

Technical specifications

Mode of operation	
Measuring principle	Temperature sensor
Input	
Measuring range	-40 ... +100 °C (-40 ... +212 °F)
Output	
Response time	
• Forced circulation (temperature variation: 63 %)	55 s
• Flange, forced circulation	90 s
• Natural convection	150 s
Rated operating conditions	
Installation instructions	Mounted indoors/outdoors, but not exposed to direct sunlight
Pressure	Max. 4 bar (60 psi/400 kPa)
Design	
Material (enclosure)	ETFE ¹⁾
Cable connection	2-core, 0.5 mm ² (20 AWG), shielded, silicone sheath
Process connection	¾" NPT [(Taper), ANSI/ASME B1.20.1] R ¾" [(BSPT), EN 10226], totally encapsulated
Certificates and approvals	
	CE, IEC Ex, FM, CSA, ATEX

¹⁾ ETFE is a fluoropolymer inert to most chemicals. For exposure to specific environments, check the chemical compatibility charts before installing the TS-3 in your application.

Dimensional drawings

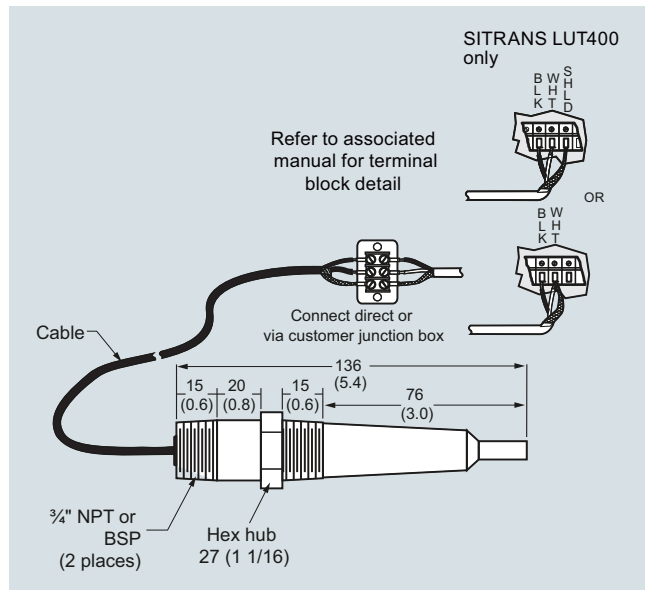

TS-3 temperature sensor, dimensions in mm (inch)

Selection and ordering data

TS-3 Temperature sensor
Continuous, non-contact, sensor for use with ultrasonic level controllers.

Click on the Article No. for the online configuration in the PIA Life Cycle Portal.

Cable length

1 m (3.28 ft)
5 m (16.40 ft)
10 m (32.81 ft)
30 m (98.43 ft)
50 m (164.04 ft)
70 m (229.66 ft)
90 m (295.28 ft)

Process connection

¾" NPT [(Taper), ANSI/ASME B1.20.1]
R ¾" [(BSPT), EN 10226]

Approvals

CSA, FM
CE, ATEX, IEC Ex

Operating Instructions

All literature is available to download for free, in a range of languages, at

<http://www.siemens.com/processinstrumentation/documentation>

Accessories

¾" NPT locknut, aluminum

Tag, stainless steel with hole, 12 x 45 mm (0.47 x 1.77 inch) for fastening on sensors

Article No.

7ML1813-

B

1

2

3

4

5

6

7

A

B

3

4

7ML1930-1BE

7ML1930-1BJ