

SAE J514/J1926 O-RING PRESSURE CONNECTION FOR 1009SW/ 1008S PRESSURE GAUGES

The National Fluid Power Association recommends the use of straight thread O-ring ports (SAE Standard J514/J1926) instead of pipe threads for fluid power components. The reason for this recommendation is to minimize the possibility of leakage which may occur with pipe threads. This connection is available on 2½" and 3 ½" dial size 1009 SW pressure gauges and 40mm, 50mm, 63mm and 100mm dial size 1008S industrial pressure gauges. The process connection code is "RW". The male thread is a 7/16-20 straight thread with an O-ring, washer and lock nut (see figure 1 and 2 for reference). This connection type allows the gauge position to be oriented as required.

PIP #: IG-PI-02

Applicable to:
25/35 1009SW
and 1008S
Pressure Gauges



Figure 1 – 2 ½" Dial 1009 Pressure Gauge with SAE-4 7/16 -20 Straight Thread Process Connection (connection code "RW")



Figure 2 – SAE-4 7/16 -20 Straight Thread Process Connection

Industries That Use SAE 7/16 -20 Straight Thread Process Connection

- Automotive
- Hydraulic Equipment
- Manufacturers of Construction Equipment
- Mining

Benefits of SAE-4 7/16 -20 Straight Thread Process Connection

- Tight sealing, even with surface imperfections and better than metal-to-metal tapered threads (NPT).
- Withstands vibration, expansion and contraction that may cause pipe threads to loosen and leak.
- Takes less time and effort to install.
- Gauge can be oriented as required prior to tightening.
- Does not need continuous tightening, sealants or tape.
- Does not damage threads and therefore, the gauge can be removed and returned to use.

Typical Installation Practices

Below are guidelines for the “RW” 7/16 -20 straight thread process connection installation.

- The Ashcroft “RW” pressure gauge connection, fitting is a SAE-4 7/16-20 straight thread with an O-ring, washer, and nut. The dimensions are in compliance with SAE J1926-2.
- The O-ring material is Viton 90A durometer per Ashcroft part number 185A106-50.
- Lubricate the threads and O-ring with 10 wt. hydraulic fluid prior to installing an Ashcroft gauge with the “RW” connection. Raise the nut prior to installing the gauge. This ensures the O-ring does not get crushed in the threads (see figure 3 and 4 for reference).
- Hand tighten the fitting of the gauge by holding the connection wrench flats and not the gauge housing until the fitting contacts the matting port surface.
- Tighten the nut on the gauge connection to 15 ft. lbs. of torque per SAE J514 (hydraulic tube fitting).

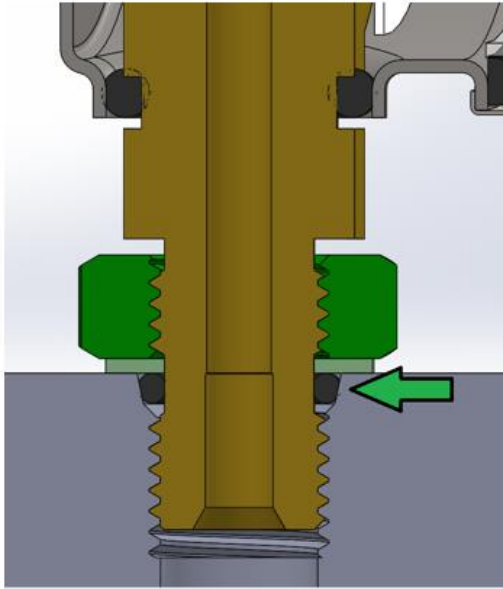

Figure 3 – Raised Nut installation to Prevent O-ring Damage

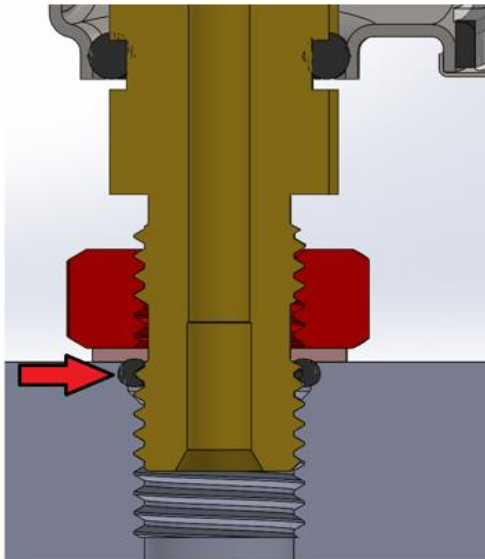

Figure 4 – Potential Leakage Due to O-Ring Distorted or Cut from Not Raising the Nut