



Nitrogen Gas Generator

NITROSource N2-20P - N2-80P

User Guide

(EN) Original Language

aerospace
climate control
electromechanical
filtration
fluid & gas handling
hydraulics
pneumatics
process control
sealing & shielding

CONTENTS - EN

1	Safety Information	3-EN
1.1	Markings and Symbols	4-EN
1.2	Personnel Definitions	4-EN
1.2.1	Generator Model Number Identification	5-EN
2	Description	6-EN
2.1	Technical Specification	6-EN
2.2	Approvals and Compliance	7-EN
2.2.1	Approvals	7-EN
2.2.2	Compliance	7-EN
2.3	Weights and Dimensions	8-EN
2.4	Materials of Construction	8-EN
2.5	Receiving and Inspecting the Equipment	9-EN
2.5.1	Storage	9-EN
2.5.2	Unpacking	9-EN
2.6	Overview of the equipment	10-EN
3	Installation and Commissioning	11-EN
3.1	Recommended System Component Layout	11-EN
3.1.1	Compressed air pre-treatment	11-EN
3.2	Locating the Equipment	12-EN
3.2.1	Environment	12-EN
3.2.2	Space Requirements	12-EN
3.2.3	Air Inlet Quality	12-EN
3.3	Mechanical Installation	13-EN
3.3.1	General Requirements	13-EN
3.3.2	Securing the Generator	14-EN
3.3.3	Making the Connections	14-EN
3.4	Electrical Installation	15-EN
3.5	General Requirements	15-EN
3.6	Customer Connections	15-EN
3.6.1	Generator Mains Voltage Supply	15-EN
3.6.2	Dryer Supply	16-EN
3.6.3	Purge Economy	16-EN
3.6.4	Alarm Contacts	16-EN
3.6.5	Remote Switching	16-EN
3.6.6	4–20mA Analogue Output	17-EN
3.6.7	MODBUS	17-EN
4	Operating the Generator	18-EN
4.1	Overview of the Controls	18-EN
4.2	Starting the generator	18-EN
4.3	Stopping the generator	19-EN
4.4	Menu Interface	19-EN
4.4.1	Hour Meters	20-EN
4.4.2	Fault Log	20-EN
4.4.3	Customer Settings	20-EN
4.5	Oxygen Content	22-EN
4.6	Economy Mode	22-EN
4.7	Energy Saving Technology - EST	22-EN
4.8	Oxygen Sensor Calibration	23-EN
5	Preventative Maintenance	24-EN
5.1	Cleaning	24-EN
5.2	Maintenance Schedule	24-EN
5.3	Preventative Maintenance Kits	25-EN
5.3.1	High Purity Generators (PPM)	25-EN
5.3.2	Low Purity Generators (%)	25-EN
5.3.3	Kit Contents	26-EN
6	Troubleshooting	27-EN
7	Declaration of Conformity	28-EN
8	Wiring Schematic	29-EN

1 Safety Information

Important: Do not operate this equipment until the safety information and instructions in this user guide have been read and understood by all personnel concerned.

WARNING - USER RESPONSIBILITY

FAILURE OR IMPROPER SELECTION OR IMPROPER USE OF THE PRODUCTS DESCRIBED HEREIN OR RELATED ITEMS CAN CAUSE DEATH, PERSONAL INJURY AND PROPERTY DAMAGE.

This document and other information from Parker-Hannifin Corporation, its subsidiaries and authorized distributors provide product or system options for further investigation by users having technical expertise.

The user, through its own analysis and testing, is solely responsible for making the final selection of the system and components and assuring that all performance, endurance, maintenance, safety and warning requirements of the application are met. The user must analyze all aspects of the application, follow applicable industry standards, and follow the information concerning the product in the current product catalog and in any other materials provided from Parker or its subsidiaries or authorized distributors.

To the extent that Parker or its subsidiaries or authorized distributors provide component or system options based upon data or specifications provided by the user, the user is responsible for determining that such data and specifications are suitable and sufficient for all applications and reasonably foreseeable uses of the components or systems.

This equipment is intended to be operated indoors and is designed to produce high purity nitrogen gas from a supply of clean dry compressed air. Please refer to the technical specification for pressure, temperature, and compressed air requirements.

Do not connect liquids or gases or to the inlet port of this generator.

Use of the equipment in a manner not specified within this user guide may result in an unplanned release of pressure, which may cause serious personal injury or damage.

Only competent personnel trained, qualified, and approved by Parker domnick hunter should perform installation, commissioning, service and repair procedures.

When handling, installing or operating this equipment, personnel must employ safe engineering practices and observe all related regulations, health & safety procedures, and legal requirements for safety.

Ensure that the equipment is depressurised and electrically isolated, prior to carrying out any of the scheduled maintenance instructions specified within this user guide.

Note: Any interference with the calibration warning labels will invalidate the gas generator's warranty and may incur costs for the re-calibration of the gas generator.

Parker domnick hunter can not anticipate every possible circumstance which may represent a potential hazard. The warnings in this manual cover the most known potential hazards, but by definition can not be all-inclusive. If the user employs an operating procedure, item of equipment or a method of working which is not specifically recommended by Parker domnick hunter the user must ensure that the equipment will not be damaged or become hazardous to persons or property.















Most accidents that occur during the operation and maintenance of machinery are the result of failure to observe basic safety rules and procedures. Accidents can be avoided by recognising that any machinery is potentially hazardous.

Details of your nearest **Parker domnick hunter** sales office can be found at www.parker.com/dhfns

Retain this manual for future reference.

1.1 Markings and Symbols

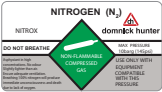
The following markings and international symbols are used on the equipment or within this manual:

	Caution, Read the User Guide.		Wear ear protection
	Risk of electric shock.		Pressurised components on the system
 Warning	Highlights actions or procedures which, if not performed correctly, may lead to personal injury or death.		Remote control. The generator may start automatically without warning.
 Caution	Highlights actions or procedures which, if not performed correctly, may lead to damage to this product.		Conformité Européenne
 Warning	Highlights actions or procedures which, if not performed correctly, could lead to electric shock.		When disposing of old parts always follow local waste disposal regulations.
	Use a fork lift truck to move the dryer.	 WARNING: MORE THAN ONE LIVE CIRCUIT AVERTISSEMENT: CET EQUIPEMENT RENFERME PLUSIEURS CIRCUITS SOUS TENSION	If remote fault indication relay is used, the electrical enclosure will now contain more than one live circuit and in the event of the mains supply being disconnected, the fault relay connections will remain live.
 NITROGEN (N ₂) NITROX DO NOT BREATHE Asphyxiant in high concentrations. No odour. Slightly lighter than air. Ensure adequate ventilation. Breathing 100% nitrogen will produce immediate unconsciousness and death due to lack of oxygen. NON-FLAMMABLE COMPRESSED GAS			Waste electrical and electronic equipment should not be disposed of with municipal waste.

1.2 Personnel Definitions

Operator - person operating equipment for its intended purpose. No access to the internal compartment of the generator.

Responsible Body - individuals or group responsible for the safe use and maintenance of equipment. Access into the internal compartment of the generator is restricted to key holders only.

Service Personnel - individuals or group that have been trained, or are qualified and approved, by Parker domnick hunter to perform installation, commissioning, service and repair procedures.

1.2.1 Generator Model Number Identification

The model number can be found on the rating plate as illustrated.

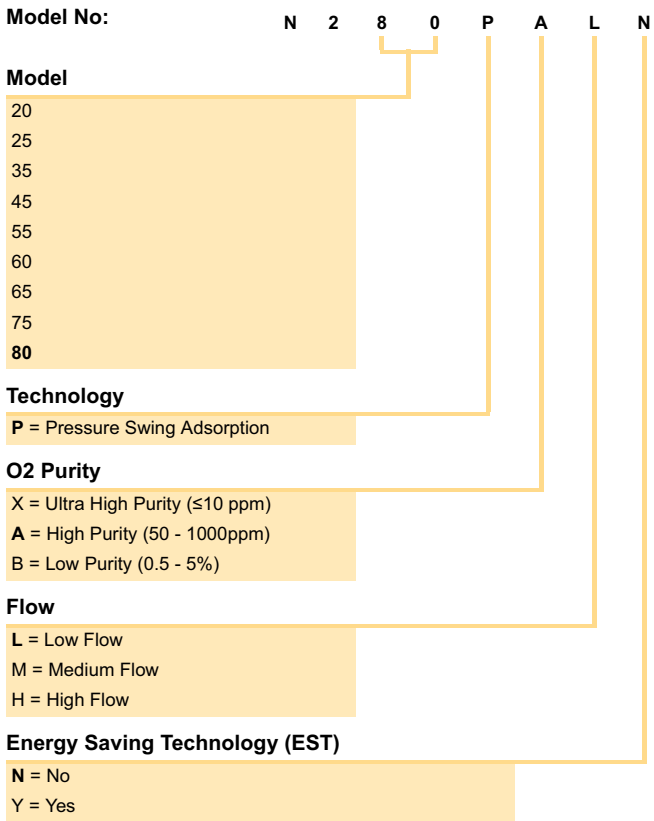

2 Description

The NITROSource PSA range of nitrogen generators operate on the Pressure Swing Adsorption (PSA) principle to produce a continuous stream of nitrogen gas from clean dry compressed air.

Pairs of dual chamber extruded aluminium columns, filled with Carbon Molecular Sieve (CMS), are joined via an upper and lower manifold to produce a two bed system. Whilst one bed is online and removing oxygen from the process air the other is regenerated.

Clean, dry particulate free compressed air enters the bottom of the online bed and flows up through the CMS. Oxygen and other trace gases are preferentially adsorbed by the CMS, allowing nitrogen to pass through. At the end of this adsorption phase the inlet, outlet and exhaust valves close on both beds. The upper and lower equalisation valves open, allowing the pressure to equalise between the beds. This equalisation phase is designed to reduce energy consumption and enhance the overall performance of the generator.

Once equalised the bed entering regeneration is depressurised. The oxygen adsorbed during the adsorption phase is vented to atmosphere via an exhaust valve and silencer. A small proportion of the outlet nitrogen gas is also expanded into this bed to help the desorption of oxygen from the CMS.

The bed entering the adsorption phase is pressurised using a controlled flow of nitrogen gas from the nitrogen buffer vessel (Back Fill) and a controlled flow of clean, dry, particulate free compressed air (Front Fill).

The CMS beds alternate between adsorption and regeneration modes to ensure continuous and uninterrupted nitrogen production.

2.1 Technical Specification

Product Selection

NITROSource PSA Performance @ 20 °C (68 °F) Ambient Air Temperature & 7 barg (101.5 psi g) Air inlet pressure															
Model		5 ppm	10ppm	50ppm	100ppm	250ppm	500ppm	0.10%	0.40%	0.50%	1%	2%	3%	4%	5%
N2-20P	m3/hr	3.5	4.5	6.7	8.0	9.7	11.1	12.4	16.7	17.7	21.3	25.3	29.8	30.9	33.7
	CFM	2.1	2.6	3.9	4.7	5.7	6.5	7.3	9.8	10.4	12.5	14.9	17.5	18.2	19.8
N2-25P	m3/hr	5.3	6.8	10.1	12.0	14.6	16.7	18.6	25.1	26.6	32.0	38.0	44.7	46.4	50.6
	CFM	3.1	4.0	5.9	7.1	8.6	9.8	10.9	14.8	15.7	18.8	22.4	26.3	27.3	29.8
N2-35P	m3/hr	7.0	9.0	13.4	16.0	19.4	22.2	24.8	33.4	35.4	42.6	50.6	59.6	61.8	67.4
	CFM	4.1	5.3	7.9	9.4	11.4	13.1	14.6	19.7	20.8	25.1	29.8	35.1	36.4	39.7
N2-45P	m3/hr	8.8	11.3	16.8	20.0	24.3	27.8	31.0	41.8	44.3	53.3	63.3	74.5	77.3	84.3
	CFM	5.2	6.7	9.9	11.8	14.3	16.4	18.2	24.6	26.1	31.4	37.3	43.8	45.5	49.6
N2-55P	m3/hr	10.5	13.5	20.1	24.0	29.1	33.3	37.2	50.1	53.1	63.9	75.9	89.4	92.7	101.1
	CFM	6.2	7.9	11.8	14.1	17.1	19.6	21.9	29.5	31.3	37.6	44.7	52.6	54.6	59.5
N2-60P	m3/hr	11.6	15.0	22.3	26.6	32.3	36.9	41.2	55.5	58.9	70.8	84.1	99.1	102.7	112.1
	CFM	6.8	8.8	13.1	15.7	19.0	21.7	24.2	32.7	34.7	41.7	49.5	58.3	60.4	66.0
N2-65P	m3/hr	13.3	17.1	25.5	30.4	36.9	42.2	47.1	63.5	67.3	80.9	96.1	113.2	117.4	128.1
	CFM	7.8	10.1	15.0	17.9	21.7	24.8	27.7	37.4	39.6	47.6	56.6	66.6	69.1	75.4
N2-75P	m3/hr	14.5	18.6	27.7	33.1	40.2	46.0	51.3	69.1	73.3	88.2	104.7	123.4	127.9	139.5
	CFM	8.5	10.9	16.3	19.5	23.7	27.1	30.2	40.7	43.1	51.9	61.6	72.6	75.3	82.1
N2-80P	m3/hr	16.1	20.7	30.8	36.8	44.6	51.1	57.0	76.8	81.4	98.0	116.4	137.1	142.1	155.0
	CFM	9.5	12.2	18.1	21.7	26.3	30.1	33.5	45.2	47.9	57.7	68.5	80.7	83.6	91.2
Air : N2 (N2-20 - N2-55)		9.3	7.2	5.1	4.6	4.1	3.7	3.4	2.9	2.8	2.6	2.3	2.2	2.2	2.1
Air : N2 (N2-60 - N2-65)		9.8	7.6	5.3	4.9	4.3	3.9	3.5	3.0	2.9	2.7	2.5	2.3	2.3	2.2
Air : N2 (N2-75 - N2-80)		10.1	7.8	5.5	5.0	4.4	4.0	3.7	3.1	3.0	2.8	2.5	2.4	2.4	2.3
Outlet	Bar g	6.0	6.0	6.0	6.0	5.9	5.9	5.8	5.8	5.7	5.7	5.6	5.5	5.4	5.4
	Psi g	87.0	87.0	87.0	87.0	85.6	85.6	84.1	84.1	82.7	82.7	81.2	79.8	78.3	78.3

Inlet Parameters

Air Quality	ISO 8573-1: 2010 Class 2.2.2 (2.2.1 with high oil vapour content)
Pressure	5 – 13 bar g (72.5 - 188.5) psi g
Temperature	5 – 50 °C (41 – 122 °F)
Purity	20.948% (wrt O ₂) 0.0314% (wrt CO ₂)

Port Connections

Air Inlet	G1"
N ₂ Outlet to Buffer	G1"
N ₂ Inlet from Buffer	G1/2"
N ₂ Outlet	G1/2"

Electrical Parameters

Generator Supply ⁽¹⁾	100 - 240 +/- 10% Vac 50/60Hz
Generator Power ⁽²⁾	55 W
Fuse ⁽³⁾	3.15 A
Max Dryer Power ⁽⁴⁾	100W

- (1) The generator does not require adjustment when connecting to 115v and 230v electrical supplies.
 (2) The power rating specified is for the generator alone and does not take in to account any pre-treatment dryer connected to the dryer supply terminals of the generator.
 (3) (Anti Surge (T), 250v, 5 x 20mm HBC, Breaking Capacity 1500A @ 250v, IEC 60127, UL R/C Fuse).
 (4) The dryer is fed directly from the generator supply.

Environmental Parameters

Ambient Temperature	5 – 50 °C (41 – 122 °F)
Humidity	50% @ 40°C (80% @ MAX ≤ 31°C)
IP Rating	IP20 / NEMA 1
Pollution Degree	2
Installation Category	II
Altitude	< 2000 m (6562 ft)
Noise	<80 dB (A)

Packed Weights and Dimensions

Model	Height (H)		Width (W)		Depth (D)		Weight	
	mm	ins	mm	ins	mm	ins	Kg	lbs
N2-20P	725.5	28.6	1994	78.5	1090	42.9	398.4	878.3
N2-25P					1260	49.6	495.4	1092.1
N2-35P					1430	56.3	580.4	1279.6
N2-45P					1600	63.0	686.4	1513.3
N2-55P	825.5	32.5			1770	69.7	782.4	1724.9
N2-60P					1935	76.2	897.4	1978.4
N2-65P	828.5	32.6			2100	82.7	997.4	2198.9
N2-75P					2275	89.6	1093.4	2410.5
N2-80P			2445	96.3	1186.4	2615.6		

2.2 Approvals and Compliance

2.2.1 Approvals

Directives

97/23/EC: Pressure Equipment Directive

2004/108/EC: Electromagnetic Compatibility Directive

2006/95/EC: Low Voltage Directive

Safety and Electromagnetic Compatibility Standards

This equipment has been tested and complies with the following European Standards:

EN 61326-1:2013 EMC - Electrical equipment for measurement, control and laboratory use. EMC requirements. (Equipment tested to: Emissions - Light, Immunity - Heavy)

BS EN 61000-3-2:2006+A2:2009 Electromagnetic compatibility (EMC). Limits for harmonic current emissions (equipment input current = 16 A per phase)

BS EN 61000-3-3:2013 Electromagnetic compatibility (EMC). Limits. Limitation of voltage changes, voltage fluctuations and flicker in public low-voltage supply systems, for equipment with rated current = 16 A per phase and not subject to conditional connection.

BS EN 61010-1:2010 Safety requirements for electrical equipment for measurement, control, and laboratory use. General requirements

General

Designed generally in accordance with ASME VIII DIVISION 1: EDITION 2010 2011a Addenda

2.2.2 Compliance

This gas generator is compliant with FDA and European Pharmacopeia Regulations for use as a medical gas generator.

2.3 Weights and Dimensions

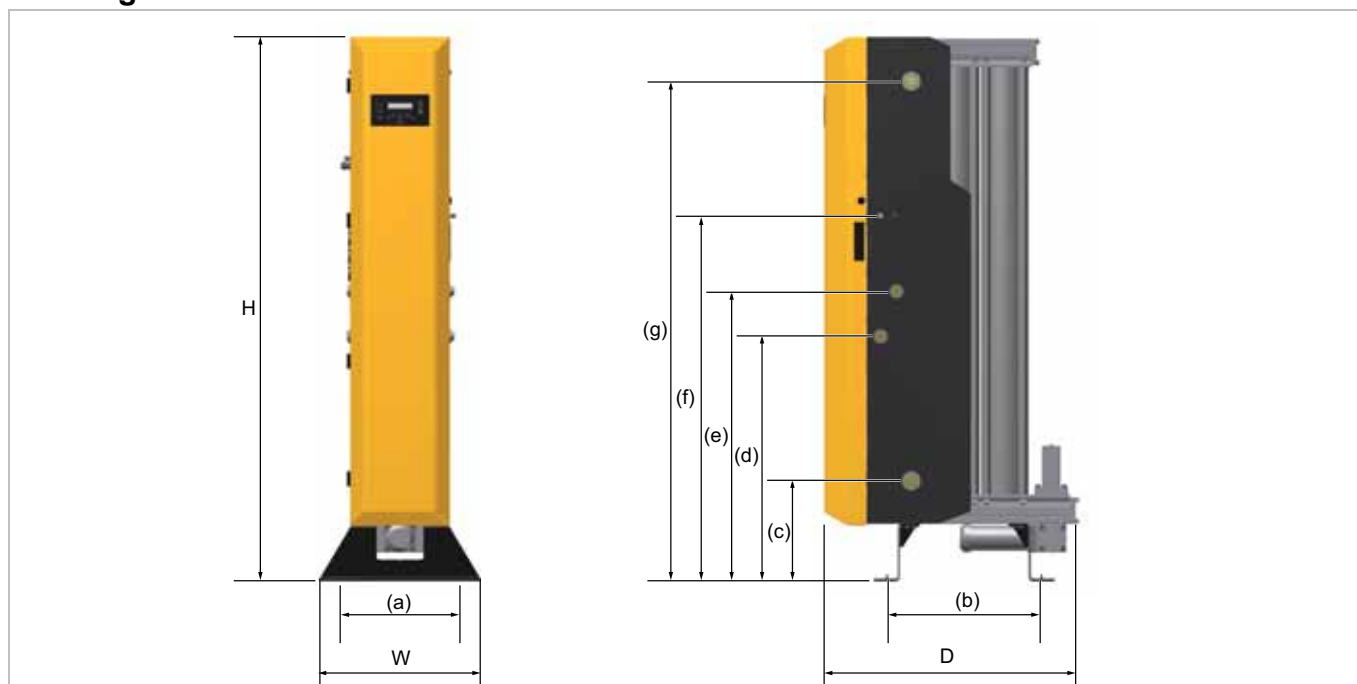

Model	Dimension																				Weight	
	H		W		D		(a)		(b)		(c)		(d)		(e)		(f)		(g)		Kg	lbs
	mm	ins	mm	ins	mm	ins	mm	ins	mm	ins	mm	ins	mm	ins	mm	ins	mm	ins	mm	ins		
N2-20P	1894	74.6	550	21.7	893	35.2	500	19.7	535.5	21.1	350	13.8	853.5	33.6	1007	39.6	1271	50	1739	68.5	299	659.2
N2-25P	1894	74.6	550	21.7	1062	41.8	500	19.7	704.5	27.7	350	13.8	853.5	33.6	1007	39.6	1271	50	1739	68.5	384	846.6
N2-35P	1894	74.6	550	21.7	1231	48.5	500	19.7	873.5	34.4	350	13.8	853.5	33.6	1007	39.6	1271	50	1739	68.5	469	1034.0
N2-45P	1894	74.6	550	21.7	1400	55.1	500	19.7	1042.5	41.0	350	13.8	853.5	33.6	1007	39.6	1271	50	1739	68.5	553	1219.2
N2-55P	1894	74.6	550	21.7	1569	61.8	500	19.7	1211.5	47.7	350	13.8	853.5	33.6	1007	39.6	1271	50	1739	68.5	638	1406.5
N2-60P	1894	74.6	550	21.7	1738	68.4	500	19.7	1380.5	54.4	350	13.8	853.5	33.6	1007	39.6	1271	50	1739	68.5	722	1591.7
N2-65P	1894	74.6	550	21.7	1907	75.1	500	19.7	1549.5	61.0	350	13.8	853.5	33.6	1007	39.6	1271	50	1739	68.5	807	1779.1
N2-75P	1894	74.6	550	21.7	2076	81.7	500	19.7	1718.5	67.7	350	13.8	853.5	33.6	1007	39.6	1271	50	1739	68.5	892	1966.5
N2-80P	1894	74.6	550	21.7	2245	88.4	500	19.7	1887.5	74.3	350	13.8	853.5	33.6	1007	39.6	1271	50	1739	68.5	976	2151.7

2.4 Materials of Construction

Silencer Baffle and End Cap	Aluminium
Columns, Manifolds and Exhaust Manifolds	Aluminium Extrusion EN AW-6063 T6
Manifold and Purge End Plates	Cast Machined EN AW-6082 T6
Inlet, Outlet and Equalisation Valve Plates	Machined EN AC-44100-F
Inlet and Exhaust Cylinders	Aluminium Alloy
Generator Feet	8MM Steel Plate
Dust Filter	Aluminium Housing
Fittings	Nickel Plated Brass and Nickle Plated Mild Steel
Pressure Gauges	Steel casing and dial, brass connector and movement
Adsorbant	Carbon Molecular Sieve (CMS)
Seal Materials	Nitrile, Viton, EPDM, PTFE (tape)
Paint	Epoxy coated

2.5 Receiving and Inspecting the Equipment

The equipment is supplied in a sturdy wooden crate designed to be moved using a forklift truck or pallet truck. Refer to the technical specification for packed weights and dimensions. On delivery of the equipment check the crate and its contents for damage and verify that the following items have been included with the generator.

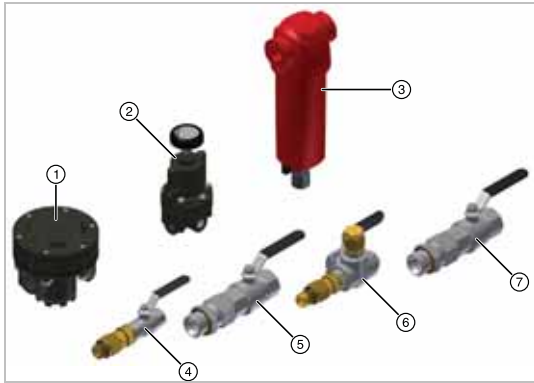

Ref	Description	Qty
1	Pilot operated regulator	1
2	Pilot regulator	1
3	Dust filter	1
4	1/2" ball valve (N2 inlet from buffer vessel)	1
5	1" BSPP ball valve (N2 Outlet to buffer vessel)	1
6	1/2" 3-way ball valve (N2 Outlet)	1
7	1" BSPP ball valve (Compressed Air Inlet)	1

If there are any signs of damage to the crate, or there are any parts missing please inform the delivery company immediately and contact your local Parker donnick hunter office.

2.5.1 Storage

The equipment should be stored, within the packing crate, in a clean dry environment. If the crate is stored in an area where the environmental conditions fall outside of those specified in the technical specification, it should be moved to its final location (installation site) and left to stabilise prior to unpacking. Failure to do this could cause condensing humidity and potential failure of the equipment.

2.5.2 Unpacking

Remove the lid and all four sides of the packing crate. Unscrew the exhaust silencer from the generator and lift the generator on to it's feet using suitable slings and an overhead crane as illustrated.



Remove the four wooden blocks from behind the shroud.

Once positioned in its final location refit the silencer to the generator.

2.6 Overview of the equipment

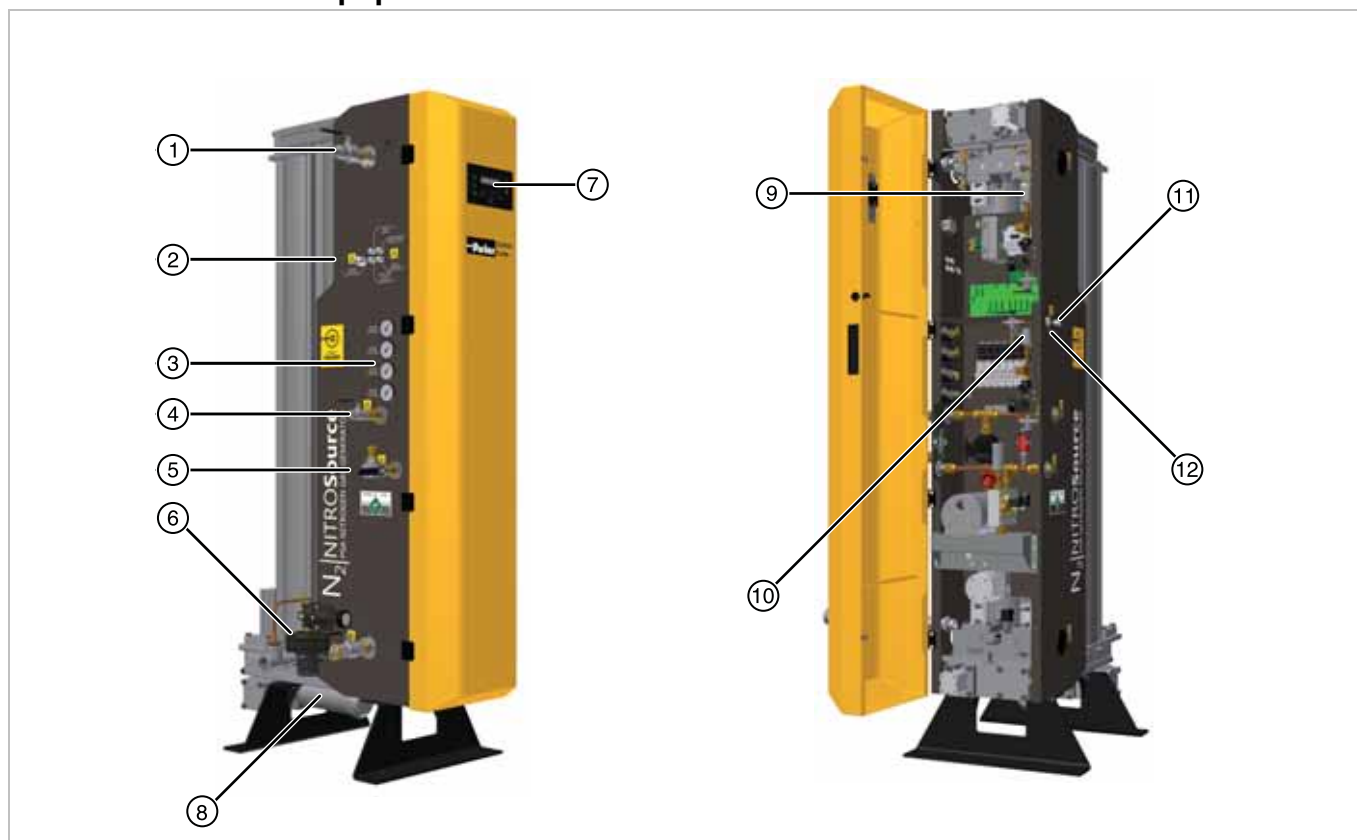

Key:

Ref	Description	Ref	Description
1	Outlet Port: To Buffer Vessel	7	User control interface with 20 x 2 line menu display
2	Cable glands	8	Exhaust silencer
3	Pressure gauges	9	Oxygen Dependant Switching (EST) Sensor (if fitted)
4	Inlet Port: From Buffer Vessel	10	Oxygen Sensor
5	Outlet Port: Nitrogen Outlet	11	4 - 20mA Cable gland
6	Inlet Port: Compressed Air Inlet with Pressure Regulator (supplied)	12	Calibration port

Note. The pressure gauges are for indication only. Items #1, #4, #5, and #6 are available on both sides of the generator.

3 Installation and Commissioning



Installation should be performed by Service Personnel only.

3.1 Recommended System Component Layout

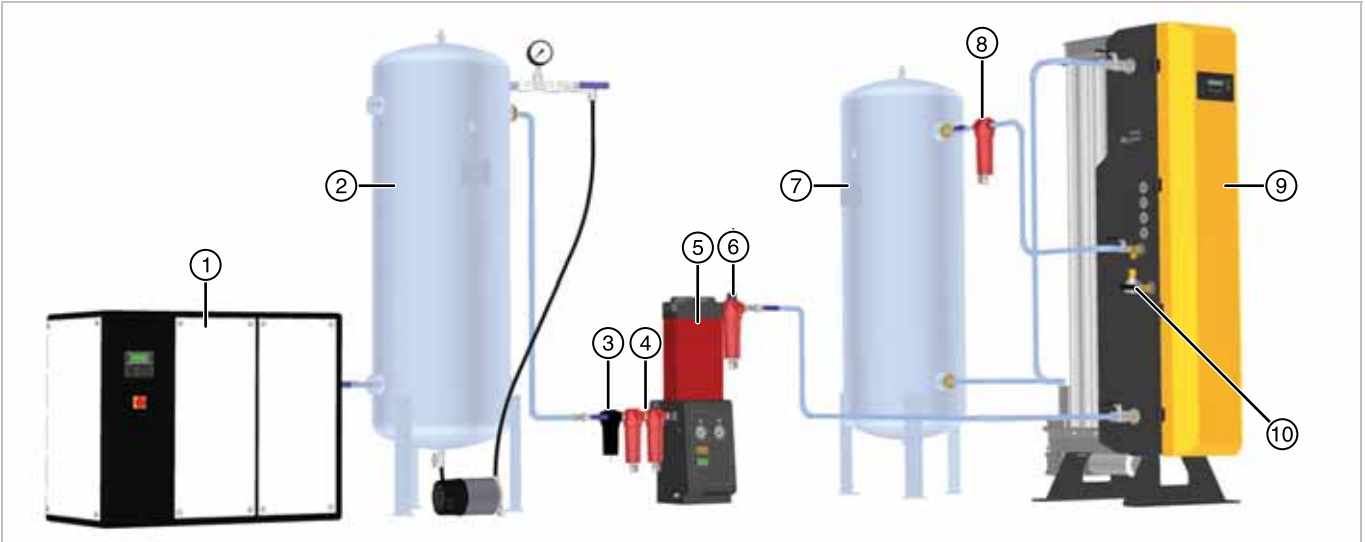

Ref	Description	Ref	Description
1	Compressor ⁽¹⁾	6	Dust filter
2	Wet air receiver complete with pressure relief valve and gauge	7	Buffer vessel
3	Water separator	8	Dust filter (supplied with the generator)
4	General purpose and dust filtration	9	Nitrogen generator
5	Compressed air dryer	10	Nitrogen Outlet to application

(1) If using an oil lubricated compressor we recommend the use of oil vapour removal filtration.



The system must be protected with a suitably rated thermal pressure relief valve upstream of the generator.

3.1.1 Compressed air pre-treatment

To achieve the maximum performance, reliability and service life, Parker domnick hunter strongly recommend the use of a Parker domnick hunter desiccant dryer based pre-treatment package.

A Parker domnick hunter Desiccant dryer pretreatment package provides a physical barrier to oil, ensures maximum generator efficiency by minimising Carbon Molecular Sieve (CMS) moisture loading and is in full compliance with the Parker 5 year warranty program.

Some applications such as pharmaceutical and food require nitrogen moisture contents that are only achievable with a desiccant dryer based pre-treatment package.

PPM generators must be operated with a Parker domnick hunter desiccant dryer based pre-treatment package.

This generator will operate with a refrigerant type dryer providing it is correctly maintained and achieves a constant pdp of +3°C, however this is the least preferred option as this type of dryer provides a minimal barrier to oil carry-over and should be strongly discouraged. It must be used in conjunction with an activated carbon Oil Vapour Removal (OVR) filter.

In certain circumstances it may also be necessary to install an OVR filter after the desiccant dryer pre-treatment package.

Note. Any contamination of the CMS due to oil or excess moisture loading will invalidate the warranty.

If in any doubt, consult your local Parker specialist for further information.

3.2 Locating the Equipment

3.2.1 Environment

The equipment should be located indoors in an environment that protects it from direct sunlight, moisture, and dust. Changes in temperature, humidity, and airborne pollution will affect the environment in which the equipment is operating and may impair the safety and operation. It is the customers' responsibility to ensure that the environmental conditions specified for the equipment are maintained.



Due to the nature of operation there is a possibility of oxygen enrichment surrounding the generator. Ensure that the area is adequately ventilated. Where the risk of oxygen enrichment is high, such as a confined space or poorly ventilated room, the use of oxygen monitoring equipment is advisable.

3.2.2 Space Requirements

The equipment should be mounted on a flat surface capable as a minimum of supporting its own weight plus the weight of all ancillary parts. The minimum footprint requirements are specified below, however there must be adequate space around the equipment to allow airflow and access for maintenance purposes and lifting equipment. A minimum spacing of approximately 500mm (20 ins) is recommended around all sides of the generator and 1000mm (39.4 ins) above it to allow service operations.

Do Not position the equipment so that it is difficult to operate or disconnect from the electrical supply.

3.2.3 Air Inlet Quality

ISO 8573-1:2010 is an international standard that specifies the purity classes of compressed air with respect to solid particulates, water and oil. The air inlet quality specified for this generator is ISO 8573-1:2010 class 2.2.2 and equates to the following:

Class 2 (Solid Particulate)

In each cubic metre of compressed air, not more than:

- 400,000 particles in the 0.1–0.5 micron size range are allowed.
- 6,000 particles in the 0.5–1 micron size range are allowed.
- 100 particles in the 1–5 micron size range are allowed.

Class 2 (Water)

A pressure dewpoint of $-40^{\circ}\text{C}/-40^{\circ}\text{F}$ or better is required and no liquid is allowed.

Class 2 (Oil)

In each cubic metre of compressed air, not more than 0.1 mg of oil is allowed.

Note. This is the combined level for aerosol, liquid and vapour.

ISO 8573-1:2010 Class 2.2.2 can be achieved with the following combination of Parker purification products:

- General Purpose filter Grade AO
- High efficiency filter grade AA
- ACS / OVR Adsorption Filter
- General Purpose Dust removal Filter Grade AR
- PNEUDRI $-40^{\circ}\text{C}/-40^{\circ}\text{F}$ PDP dryer

3.3 Mechanical Installation

3.3.1 General Requirements



The system must be protected with a suitably rated thermal pressure relief valve upstream of the generator.

Please familiarise yourself with the local regulations before considering any pipe-work installation as standards and specifications for pipe-work systems can vary greatly from country to country. The information below is a guide based on installations performed within Europe.

Nitrogen, besides being inert, is also widely used because it is considered a clean dry gas.

Many of the processes that use nitrogen are of a critical nature and apart from contamination with oxygen, the removal of dirt particulate, oil and water vapour from the gas stream is also essential. Therefore the pipe-work system and material that will transfer the nitrogen to its destination should not add any unwanted contamination into the gas stream.

All components used within the system must be rated to at least the maximum operating pressure of the equipment. Buffer and nitrogen storage vessels should be clean and free from oil and grease, and fitted with a suitable pressure gauge and pressure relief valve.

If there is any possibility of particulate contamination then this can be removed by installing a suitable Oil-X Evolution filter as near to the point of use as possible. Ensure that each filter condensate drain is suitably piped away and any effluent is disposed of in accordance with local regulations.

The compressed air feed pipe-work to the pre-treatment package should be suitable for compressed air duty and of a size and construction to handle the maximum flow and pressures involved. Materials such as medium weight galvanized, Transair or similar are acceptable. As much cutting fluid, oil and grease as possible should be removed from the pipe-work and fittings prior to connecting.

From the pre-treatment onwards and for the nitrogen gas, the pipe-work needs to be clean and oil-free.

If using a modular pipe-work system such as Transair, oil and grease should be removed using a suitable cleaner (if necessary) from the surfaces that come into contact such as the pipe-work including fittings.

The most commonly used material for installing nitrogen pipe-work is table "X" de-greased copper. This should be silver soldered with a nitrogen purge where ever possible and for threaded interfaces general heavy duty (GHD) fittings should be used. For small bore pipe-work, it is sometimes acceptable to use compression type fittings or crimp type pipe-work systems. For food and pharmaceutical installations, welded or threaded stainless steel is often specified, especially where it enters the production environment. For these market sectors the inclusion of sterile filtration such as the "High Flow BIO-X" is advisable to ensure even the remote possibility of contamination from microorganisms is prevented.

In general flexible hoses should be avoided. They are almost certainly not suitable for high purity <100 ppm applications.

However, if they are to be used, ensure they are suitable for use with an inert gas. Certain materials such as nylon tubing can actually permeate oxygen from outside to inside and affect the purity of the nitrogen gas. PTFE flexible tubing is preferred.

When routing the pipes ensure that they are adequately supported to prevent damage and leaks in the system.

The diameter of the pipes must be sufficient to allow unrestricted inlet air supply to the equipment and outlet nitrogen supply to the application. The following table gives guidance on the maximum recommended flow rates for smooth bore pipe-work.

		Pressure							
		4 bar g	58 psi	6 bar g	87 psi	8 bar g	116 psi	10 bar g	145 psi
		Recommended Flowrate							
		m ³ /hour	cfm	m ³ /hour	cfm	m ³ /hour	cfm	m ³ /hour	cfm
Pipe size I/D (or Equivalent)	16mm	28.8	17.0	43.2	25.4	64.8	38.1	75.6	44.5
	20mm	36.6	21.5	57.6	33.9	82.8	48.7	101.0	59.4
	25mm	68.4	40.3	111.0	65.3	155.0	91.2	194.0	114.2
	32mm	152.0	89.5	227.0	133.6	295.0	173.6	385.0	226.6
	40mm	306.0	180.1	432.0	254.3	576.0	339.0	702.0	413.2
	50mm	440.0	259.0	698.0	410.8	940.0	553.3	1213.0	713.9
	63mm	824.0	485.0	1318.0	775.7	1771.0	1042.4	2326.0	1369.0
	75mm	1296.0	762.8	2034.0	1197.2	2847.0	1675.7	3510.0	2065.9
	90mm	2052.0	1207.8	3186.0	1875.2	4576.0	2693.3	5490.0	3231.3
	110mm	3600.0	2118.9	5652.0	3326.6	7956.0	4682.7	9756.0	5742.2

3.3.2 Securing the Generator



The generator **MUST** be fixed in position using suitable M20x40mm Rawl bolts (or equivalent). Mounting holes are provided in the feet of the generator.

3.3.3 Making the Connections

Refer to the "Recommended System Component Layout" on page 11 for the desired system configuration.

Port connections are provided on both sides of the generator. Connect the ball valves supplied to the ports, using PTFE tape on the threads to provide a leak free seal.

Assemble the inlet pressure regulator as illustrated below taking note of the flow directions marked on the underside of the pilot operated regulator.

Use PTFE tape on the threads to provide a leak free seal.

Note. Fittings are not supplied.

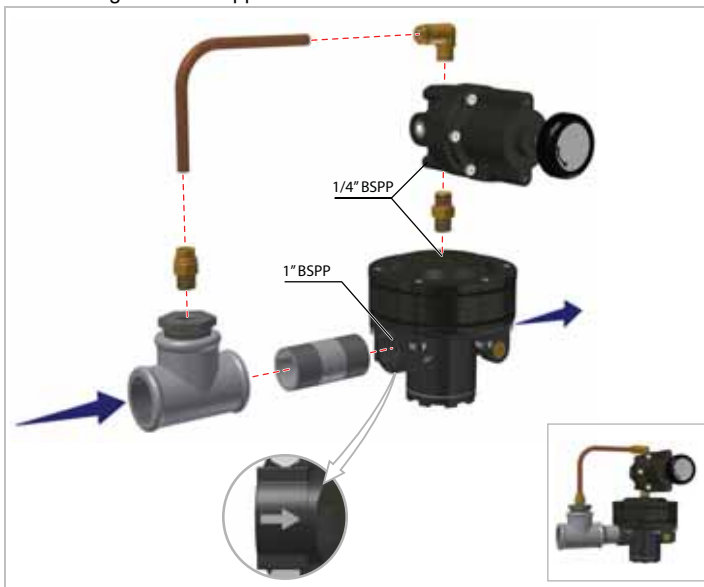

When installing the 3-way ball valve to the Nitrogen Outlet port ensure that it is positioned in a vertical position and so that there is unrestricted access to the centre port for the connection of a flow meter.

Install the pipe-work ready for connection to the buffer vessel and compressed air supply. We recommend that additional ball valves are connected to the buffer vessel ports to allow it to be isolated during maintenance activities.

Setting the inlet Pressure Regulator

The inlet pressure must be set prior to running the generator.

- 1 Adjust the internal Inlet / Outlet pressure ball valve to the **Inlet Pressure** position (pointing down).
- 2 Power up the generator and navigate to menu 3.5. The inlet compressed air pressure will be displayed.
- 3 Check the rating plate for the required set pressure then adjust the regulator until the required set pressure is displayed on menu 3.5.
- 4 Tighten the lock nut on the regulator adjustment handle to prevent inadvertent adjustment.
- 5 Reposition the internal Inlet / Outlet pressure ball valve to the **Outlet Pressure** position (pointing upwards).

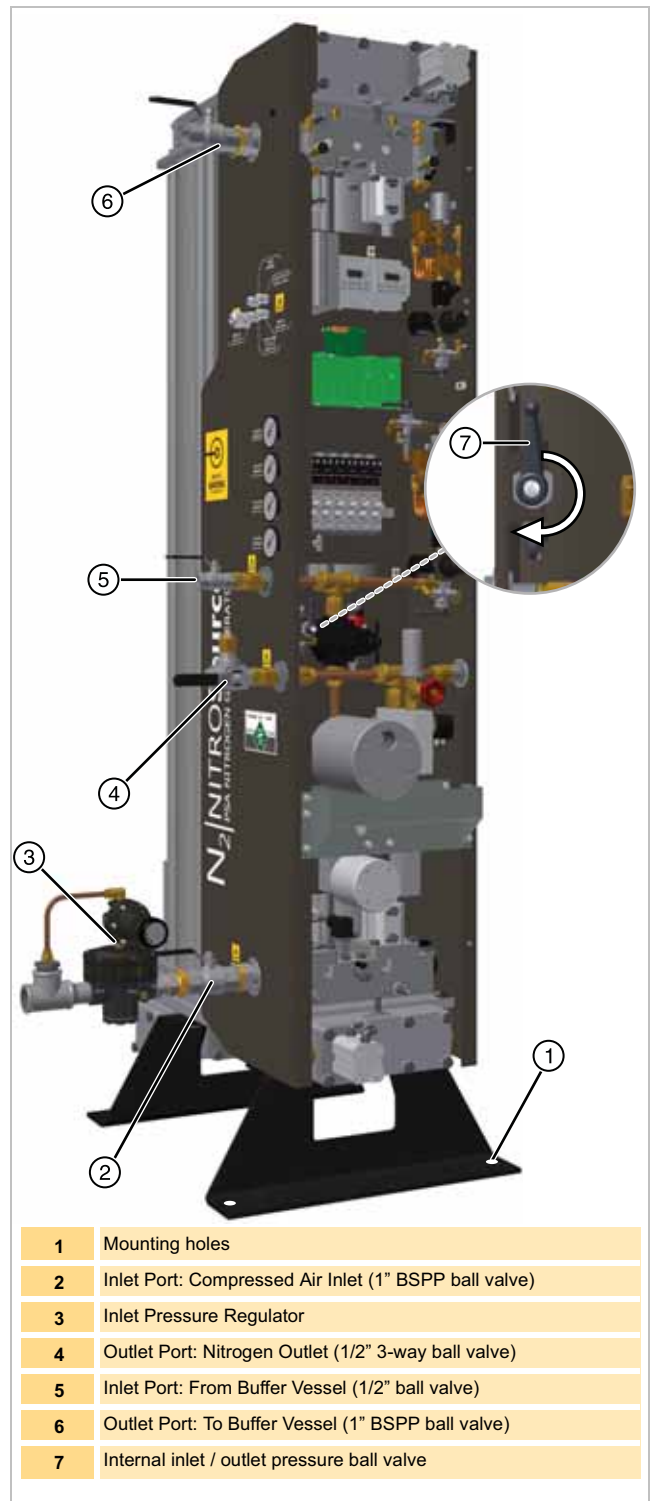

1	Mounting holes
2	Inlet Port: Compressed Air Inlet (1" BSPP ball valve)
3	Inlet Pressure Regulator
4	Outlet Port: Nitrogen Outlet (1/2" 3-way ball valve)
5	Inlet Port: From Buffer Vessel (1/2" ball valve)
6	Outlet Port: To Buffer Vessel (1" BSPP ball valve)
7	Internal inlet / outlet pressure ball valve

3.4 Electrical Installation

Warning
A fully qualified electrical engineer must undertake all field wiring and electrical work in accordance with local regulations.

3.5 General Requirements

In order to maintain the IP rating of the generator, all cables entering the electrical enclosure must do so through the dedicated cable glands located on the side of the generator. All cables used must be sized such that the voltage drop between the supply and the load does not exceed 5% of the nominal voltage under normal conditions. All cables external to the generator must be adequately supported and protected against physical damage.

When connecting to terminal blocks always ensure that the conductors are fully inserted into the terminal, and the terminal screws are firmly secured. We recommend that individual conductors are cable tied together so that, in the event of one conductor coming loose, they cannot touch other parts.



3.6 Customer Connections

Please refer to the wiring schematic at the rear of this guide for wiring details.

3.6.1 Generator Mains Voltage Supply

Terminals	Description	Minimum Conductor Size	Cable size
TB1 - L1	Fuse terminal for the phase conductor	1mm ²	8 - 12mm
TB1 - N	Neutral conductor		
TB1 - 	Earth conductor		

The generator requires a 100 - 240Vac single phase electrical supply in accordance with local wiring regulations. Refer to the technical specification for voltage and frequency tolerances.

Connection to the electrical supply should be made through a switch or circuit breaker rated at 250VAC, 6A with a minimum short circuit rating of 10KA. All of the current carrying conductors should be disconnected by this device. This protection should be selected in accordance with local and national code regulations.

The device chosen should be clearly and indelibly marked as the disconnecting device for the equipment and be located in close proximity to the equipment and within easy reach for the operator.

Over current protection must be fitted as part of the building installation. This protection should be selected in accordance with local and national code regulations with a minimum short circuit rating of 10KA.

The protective earth conductor should be longer than the associated phase conductors so that in the event of the cable slipping in the cable gland, the earth will be the last to take the strain.

Note. If using flexible cable please ensure that it conforms to the requirements of IEC60227 or IEC60245.

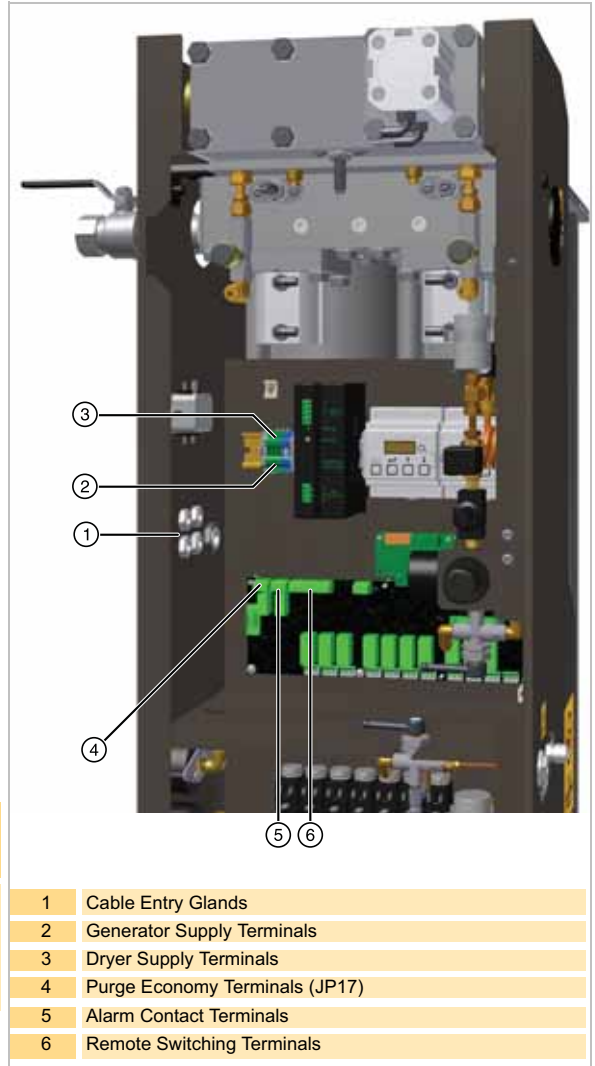

1	Cable Entry Glands
2	Generator Supply Terminals
3	Dryer Supply Terminals
4	Purge Economy Terminals (JP17)
5	Alarm Contact Terminals
6	Remote Switching Terminals

3.6.2 Dryer Supply

Terminals	Description	Cable size
TB1 - L1	Live conductor	3 - 7mm
TB1 - N	Neutral conductor	
TB1 - 	Earth conductor	

If a Parker donnick hunter pre-treatment air dryer is used, it should be connected to the generator at the dedicated DIN rail terminals. Refer the documentation provided with your dryer for additional information on installation requirements.

3.6.3 Purge Economy



Do Not connect mains electricity to the Purge Economy Terminals.

Terminals	Description	Cable size
JP17 - 2	Common	3 - 7mm
JP17 - 3	Normally Open	

If the pre-treatment dryer is fitted with a purge economy feature, it may be controlled using the volt free relay contacts on JP17. The relay is energised only when the generator enters standby mode. Refer to the documentation provided with your dryer for details on purge economy.

3.6.4 Alarm Contacts

Terminals	Description	Cable size
JP18 - 1	Normally closed	3 - 7mm
JP18 - 2	Common	
JP18 - 3	Normally open	

Each generator is fitted with a set of volt free relay contacts designed for remote alarm indication and are rated 1A max @ 250Vac (1A @ 30Vdc). Under normal operation the relay will be energised and the alarm circuit will be open. When a fault occurs, e.g. power failure, the relay will de-energise causing the alarm circuit to be complete.

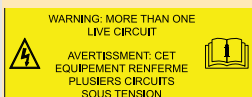

If remote fault indication relay is used, the electrical enclosure will now contain more than one live circuit and in the event of the mains supply being disconnected, the fault relay connections will remain live.

3.6.5 Remote Switching

Terminals	Description	Cable size
JP19 - 7	Common	3 - 7mm
JP19 - 8	Normally Open	

The generator may be controlled remotely by connecting a remote start / stop circuit to digital input #4 on the control board. When the circuit is open the generator should remain in standby mode, closing the circuit should initiate a start command.

To enable the remote switching function refer to 4.4.3 of this guide. Once the remote switching function has been enabled the local start control will no longer function.



When the remote switching function is enabled the generator can start without warning.

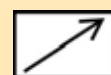

3.6.6 4–20mA Analogue Output

Terminals	Description	Cable size
Analyser - #6	Positive	3 - 7mm
Analyser - #7	Negative	

The oxygen content detected by the generators internal analyser may be re-transmitted to external peripherals using the 4-20mA linear analogue output. The output is a linear current source, with 10 bit resolution, which increases from 4mA (Zero Oxygen) to 20mA (Full Scale Deflection). The FSD of the internal analyser is factory set to a default value of twice the generators specified purity. For % purity generators the maximum FSD is set to 6%. The oxygen purity setting of the generator is marked on the rating plate. The table below shows the correlation between the purity settings of the generator and the output current.

It is recommended that the cable used for the 4-20mA Analogue Output is screened twisted pair. Ferrites should be added to the cable, using 1 turn, either side of the shroud cable gland. It is recommended that the cable used does not exceed 30m in length. Suitable ferrites are available from Wurth Electronics (P/N. 74271633S).

Generator Purity	Full Scale Deflection			Resolution		
	4mA	-	20mA		=	
5ppm	0	-	10ppm	1ppm	=	1.6mA
10ppm	0	-	20ppm	1ppm	=	0.8mA
50ppm	0	-	100ppm	1ppm	=	0.16mA
100ppm	0	-	200ppm	1ppm	=	0.08mA
250ppm	0	-	500ppm	1ppm	=	0.032mA
500ppm	0	-	1000ppm	1ppm	=	0.016mA
0.1%	0	-	0.2%	0.01%	=	0.8mA
0.4%	0	-	0.8%	0.01%	=	0.2mA
0.5%	0	-	1%	0.01%	=	0.16mA
1%	0	-	2%	0.01%	=	0.08mA
2%	0	-	4%	0.01%	=	0.04mA
3%	0	-	6%	0.01%	=	0.026mA
4%	0	-	6%	0.01%	=	0.026mA
5%	0	-	6%	0.01%	=	0.026mA

3.6.7 MODBUS

Terminals	Description	Cable size
RS485 MODBUS - A	For MODBUS communication setup details refer to dh publication 176500120	3 - 7mm
RS485 MODBUS - A		

The generator's controller is capable of supporting direct Modbus communication via its integral RS485 connection. This industry standard connection allows multiple generators to communicate with a remote Modbus master on a network up to 30m in length. The generator can be programmed with its own unique address, to allow multiple generators to be connected to an existing network.

4 Operating the Generator

4.1 Overview of the Controls

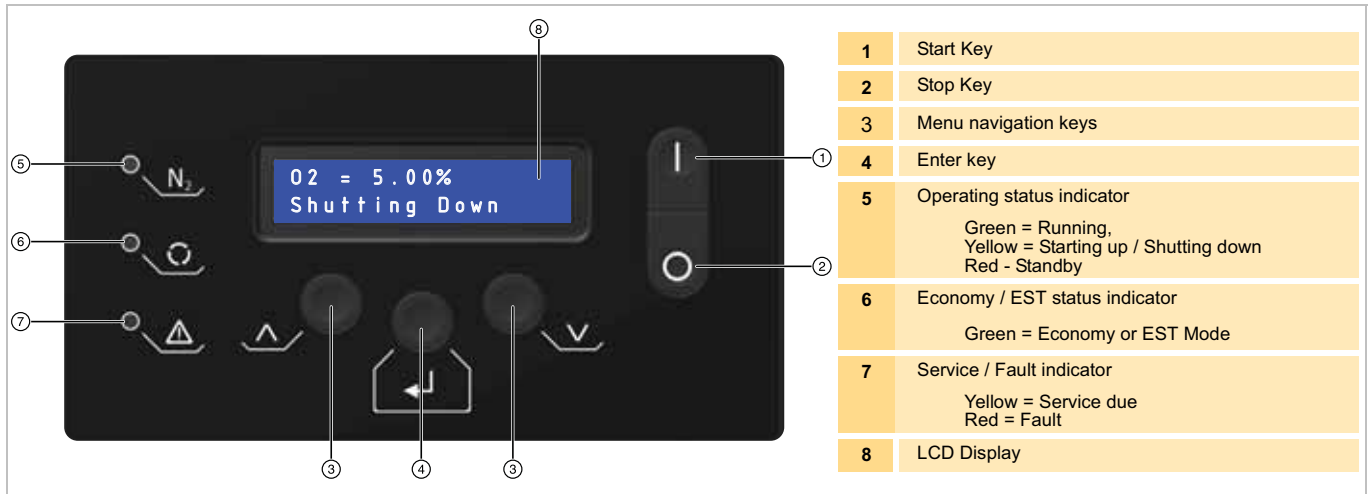

4.2 Starting the generator

- 1 Inspect all of the system connection points and verify that they are secure.
- 2 With both the inlet and outlet ball valves of the buffer vessel closed, open the ball valve on the air inlet port to allow the compressed air into the generator.
- 3 Switch the electrical power on to the generator and wait whilst it runs through the controller initialisation routine.
- 4 If the generator was in standby mode when the electrical power was removed it will default to standby mode on completion of the initialisation routine.

S t a n d b y
- 5 Press **1** to initiate the start up routine.
If the start clean up option is enabled the generator will run through the Rapid Cycle before opening the buffer valve and the N2 outlet valve. The clean up cycle, which takes approximately 160 seconds, is designed to clean the CMS bed of impurities, bring the generator up to production purity more rapidly, and prevent poor quality gas flowing into the buffer.

O2 = 5.00%
R a p i d C y c l e

If the generator was running when the electrical power was removed (e.g. power failure) it will automatically run through a start up cycle (if enabled) and then commence normal operation. Wait until this cycle is complete and the menu displays "Running". This may take several minutes for ppm generators.

- 6 Partially open the ball valve on the inlet to the buffer vessel to allow it to pressurise slowly. When the pressure gauge on the buffer vessel reads within 0.5 barg (7psig) of the inlet pressure, check for leaks in the buffer vessel inlet piping and then fully open the ball valve.
- 7 Open the ball valve on the outlet of the buffer vessel and check for leaks in the piping between the vessel and the generator.
- 8 Open the ball valve on the Nitrogen outlet.

Note: If the purity of the gas is not within specification it will be vented to atmosphere through a vent solenoid within the generator and not delivered to the application. When the required purity is achieved the gas will be delivered to the application.

4.3 Stopping the generator

- 1 Close the ball valve on the N2 Outlet port.
- 2 Press  to initiate the shutting down sequence.

The generator will complete the current cycle and then exhaust both beds. This may take several minutes particularly on ppm generators.

- 3 When the generator is depressurised it will revert to standby mode.

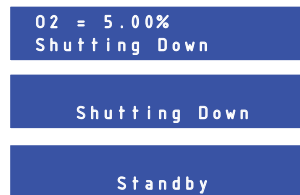

4.4 Menu Interface

All of the operational parameters and data are accessed through the menu driven interface..

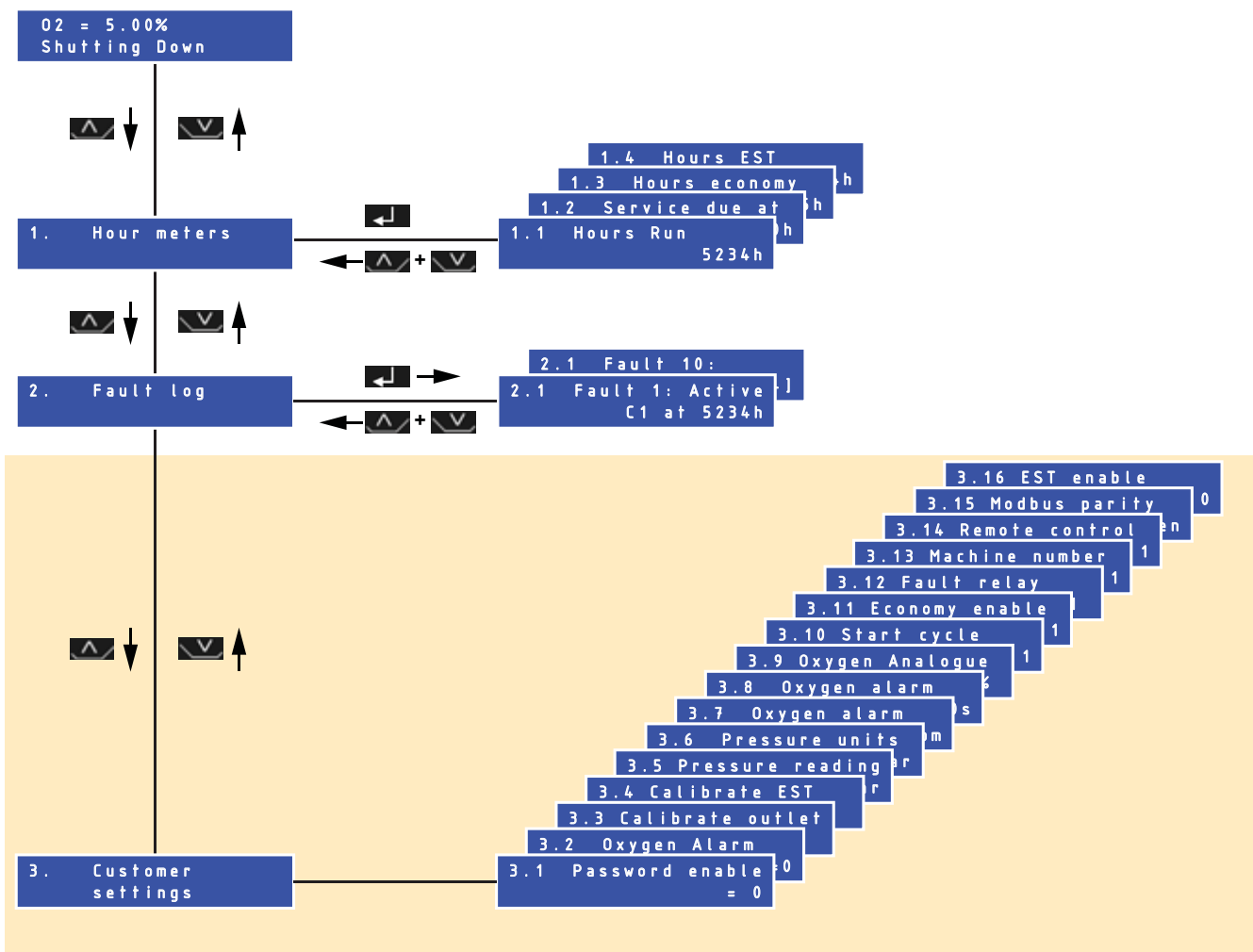





The interface will automatically default back to the main operating menu if no key activity has been detected for one minute.

Note: After an additional two minutes of inactivity the display will darken. To brighten the display press .

4.4.1 Hour Meters

There are four hour meters available for viewing:

	The time in hours that the generator has been producing gas.
	The time in operating hours that the generator can produce gas before a service is required.
	The time in hours that the generator has been operating in Economy mode.
	The time in hours that the generator has been operating in EST mode.

4.4.2 Fault Log

The fault log menu allows the user to access the 10 most recent fault messages.



	Each fault is represented by a fault code and is displayed along with the run hours at which the fault occurred. If a fault is active the fault code displayed will flash. Any faults that are active when the power is switched off, and are still active when the power is re-applied, will cause a new entry to be added into the fault log.
---	---

Refer to “Fault Codes” on page 27 for a full listing of fault codes.



4.4.3 Customer Settings



To prevent unauthorised access to the configurable parameters, the customers setting menu has optional password protection. This is disabled by default and can be enabled in menu 3.1







To gain access in to this menu, when password has been enabled:

Press and hold both the  and  keys for approximately 5 seconds until the menu changes to the password prompt as shown.





The flashing cursor will be positioned over the first digit. Using the  key change the first digit of the code and press . The cursor will move to the next digit.

Repeat the process and enter the following password 1 2 1 __. When the password has been entered correctly the Hour Meters menu will be displayed. Use the  key to navigate to page 3 “Customer Settings” menu and press .



	When enabled the end user is required to enter a password to gain access to the customer configuration menu. 0 = Disabled, 1 = Enabled
	When enabled the Oxygen alarm is over-ridden. 0 = Over-ride disabled, 1 = Override Enabled [OVR]
	Outlet oxygen sensor calibration menu. Refer to section 4.8 for details on calibration.
	EST oxygen sensor calibration menu. Refer to section 4.8 for details on calibration.
	Displays the outlet pressure in real time. Also used for the inlet pressure set up.
	Sets the units of measure for the outlet pressure. Units available are Bar / Psi / Mpa



3.7 Oxygen alarm level = 15 ppm	Sets the purity level at which an oxygen fault is initiated. Default Settings: % Generators - 0.05% above the selected production purity. ppm Generators - 5ppm above the selected production purity.
3.8 Oxygen alarm delay = 60 s	If the purity level exceeds the oxygen alarm level for a period longer than the alarm delay, the oxygen alarm will be activated and the gas will be vented to atmosphere. Delay Range = 0 – 600 Seconds, Default = 60 Seconds
3.9 Oxygen Analogue FSD = 6.0%	Sets the Full Scale Deflection value for the 4 – 20mA Analogue Output of the Oxygen sensor(s).
3.10 Start cycle enable = 1	When enabled the bed cleaning cycles will run whenever the generator is powered up, comes out of standby mode and economy mode. 0 = Disabled, 1 = Enabled
3.11 Economy enable = 1	Enables the economy mode. 0 = Disabled, 1 = Enabled
3.12 Fault relay on stop = 1	When enabled the actuation of the Stop control will generate an alarm. 0 = Disabled, 1 = Enabled
3.13 Machine number = 1	Sets the address for the generator when communicating on a network via the RS485 MODBUS port. Address range is 1 – 247
3.14 Remote control = 1	Sets the mode of control for the generator 1 = Local Start / Stop control, 2 = Remote Start / Stop control via the digital input, 3= Remote communication
3.15 Modbus parity = Even	Sets the parity for Modbus communication. Even, Odd, None2, None1 Note. None2 and None1 refer to no parity with two or one stop bits.
3.16 EST enable = 0	Enables the EST mode. 0 = Disabled, 1 = Enabled



Changing Parameters

Use the  and  keys to scroll through to the desired menu and press .

The flashing cursor should be positioned over the “=” sign to indicate that the parameter may be changed.

Use the  /  keys to change the parameter.

Press  to accept the changes or press  and  simultaneously to cancel the changes.

Press  and  simultaneously to return to the customer settings menu and then again to return to the main operating menu.

3.6 Pressure units = Bar

3.6 Pressure units = Bar

3.6 Pressure units = PSI

4.5 Oxygen Content

The residual oxygen content of the N2 process gas is continually monitored during normal operation. If the oxygen content increases above the alarm level the nitrogen gas is vented to atmosphere at a reduced flow until the purity recovers.

4.6 Economy Mode

Economy mode is designed to switch the generator into standby mode when there is no demand for gas.

The generator monitors the outlet pressure and, if it exceeds a pre-determined level for a sustained period of time (Economy Period *), the N2 outlet valve will close. The generator will continue to cycle as normal without delivering gas to the application. If the back pressure is maintained for an additional 5 minutes, the generator will stop cycling and enter Economy mode. If at any time the pressure falls below the regulated outlet pressure, the generator will resume normal operation.

If the generator is in economy shutdown when the pressure falls it will complete the cycle and then run through the a clean up cycle prior to going back online..



The economy mode can be disabled within the customer settings menu, however Parker domnick hunter strongly recommend that this option remains enabled.

The Economy over-ride facility (optional) can be used to maintain the beds when the generator is in economy mode. If the over-ride is enabled, a clean up cycle will be performed once every 20 minutes (default). This allows the generator to go straight on-line when the outlet pressure falls below the regulated outlet pressure.

*The Economy Period is factory set to 5 minutes.

4.7 Energy Saving Technology - EST

If the generator is not operating at full capacity, it is unlikely that the CMS in the on-line chamber will be fully saturated at the point of changeover.

The EST system is used to monitor the O2 content of the gas at both the outlet of the buffer vessel and directly from the CMS bed. If the O2 content is below the production purity by >5% at the outlet **and** >20% from the CMS bed at the end of the current cycle, the EST system extends the cycle of the generator and changeover is delayed. Depending upon the production purity requirements, the generator will remain in this state for up to 300 seconds.

If at any point the O2 content of the gas rises to within 5% (at the outlet) **or** 20% (from the CMS bed) of the production purity the generator will resume normal cyclic operation.

Note. The economy mode described above will override the EST as required.

4.8 Oxygen Sensor Calibration



The following procedure must be carried out only by a Responsible Body or Service Personnel only. Operators should not perform this operation.



Hot surfaces and hazardous live voltages. Take care when performing the following calibration procedure as there are hazardous live voltages and potentially hot surfaces within the enclosure.

The O₂ sensor(s) should be checked every 3 months and calibrated, if required, using a calibrated gas supply.

Note. The purity of the calibration gas should be as close to the production gas purity as possible (minimum of 50ppm). **Do not exceed 7bar g (101.5psi g) pressure.**

If the generator is fitted with a second O₂ sensor for EST (as illustrated) both sensors must be calibrated at the same time.

For low purity applications the calibration may be performed using compressed air. This method is not recommended when the purity of the gas is critical.

- 1 Navigate to menu 3.2 and enable the Oxygen Alarm Over-ride.
- 2 If using a calibrated gas supply - connect the gas to the Calibration Port on the side of the generator.
- 3 Locate the calibration ball valve and rotate the handle clockwise so that it is pointing towards **Calibration from Calibrated Gas position**.

Note. The calibration ball valve should be left in its original position if using compressed air.

- 4 Rotate the handles of the Outlet Gas O₂ Sensor ball valve and the CMS Gas O₂ Sensor ball valve (if fitted) 180° so that they are pointing towards the **Calibration** (as indicated on the calibration label).
- 5 Wait approximately fifteen minutes for the O₂ reading to stabilise.
- 6 Navigate to menu 3.3 and press .

Using the  and  keys enter the purity of the calibration gas.

Press  to send the calibration level to the O₂ Analyser.

On successful completion of the calibration the new O₂ reading will be shown on the bottom line of the display.

If the calibration is not successful the original reading from the analyser will be loaded. Should this occur repeat the above steps.

- 7 Repeat step 6 for the EST sensor (if fitted) in menu 3.4.
- 8 On completion of the calibration, return the ball valves back to their original position and remove the regulated calibration gas supply as applicable.
- 9 Navigate to menu 3.2 and disable the O₂ Alarm Over-ride.

When returning to the main operating menu, "CAL" will be shown on the top line of the display. This will remain for a period of twenty minutes after the calibration. Throughout this time period the O₂ alarm is overridden, to allow the sensor(s) to return to the required level.

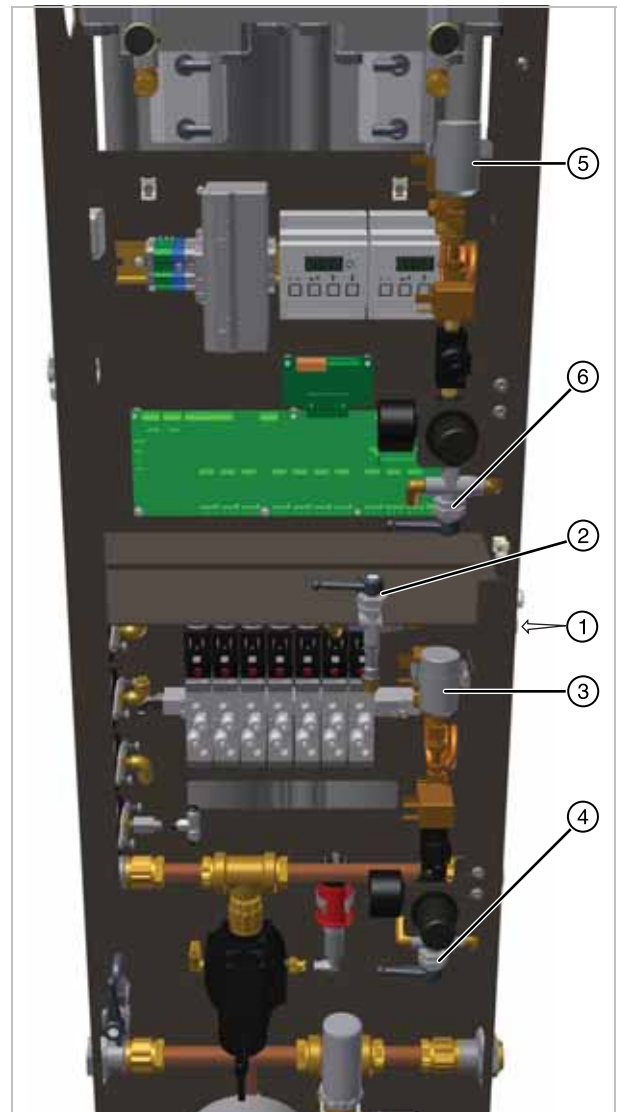

1	Calibration Port
2	Calibration ball valve
3	Outlet Gas O ₂ Sensor
4	Outlet Gas O ₂ Sensor ball valve
5	CMS Gas O ₂ Sensor (EST)
6	CMS Gas O ₂ Sensor (EST) ball valve

Note. The ball valves are shown in the normal operation position and should be returned to this position on completion of the calibration.

5 Preventative Maintenance

5.1 Cleaning



Clean the equipment with a damp cloth only and avoid excessive moisture around any electrical sockets. If required you may use a mild detergent, however do not use abrasives or solvents as they may damage the warning labels on the equipment.

5.2 Maintenance Schedule

Description Of Service Required		Service Recommended Every: ¹						
Component	Operation	Daily	3 Months (2000 Hrs.)	6 Months (4000 Hrs.)	12 Months (8000 Hrs.)	24 Months (16000 Hrs.)	36 Months (24000 Hrs.)	60 Months (40000 Hrs.)
Generator	Check the status indicators located on the front panel.	👁️						
System	Check the inlet air quality.		👁️					
Generator	Check for air leaks		👁️					
Generator	Check the pressure gauges during purging for excessive back pressure.		👁️					
Generator	Check the condition of the electrical supply cables and conduits.		👁️					
Generator	Check oxygen sensor(s) and calibrate if necessary		🔄					
Generator	Check for cyclic operation			👁️				
Filtration	Replace Exhaust silencer and filter element(s) Recommended Service A				🔧			
Generator	Replace Oxygen sensor(s) Recommended Service B					🔧		
Generator	Replace control valves Recommended Service C						🔧	
Generator	Replace cylinder and solenoid valves Recommended Service D							🔧

1. The service operations should be performed at the hours run or fixed time intervals specified (whichever occurs first)

Key:

	Check (Operator)		Essential Procedure (Service Personnel only)		Essential Procedure (Responsible Body or Service Personnel only)
---	------------------	---	--	--	--

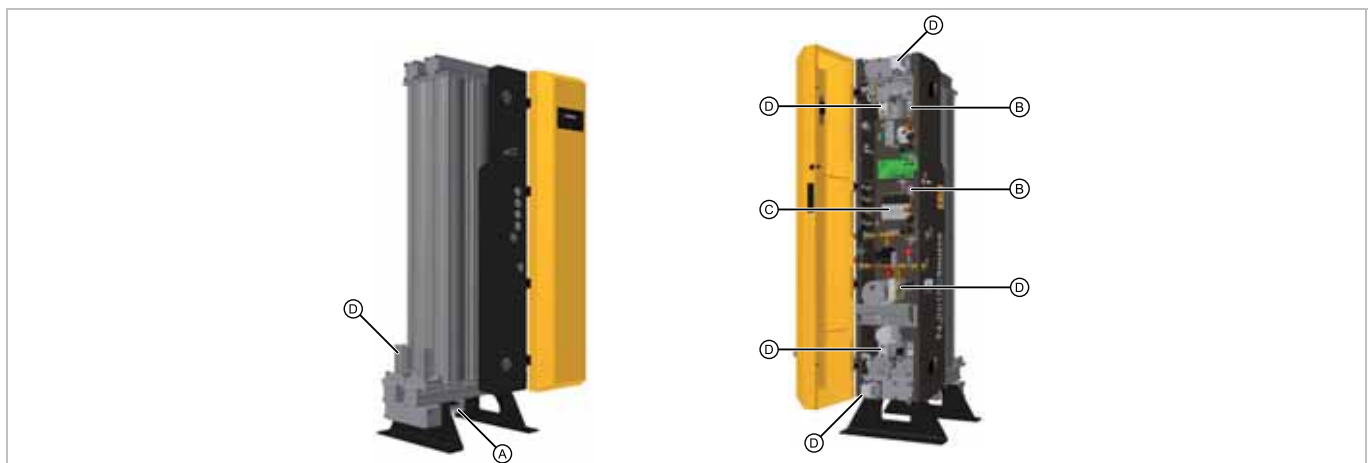

5.3 Preventative Maintenance Kits

The following preventative maintenance kits must be installed by service personnel only.

5.3.1 High Purity Generators (PPM)

Generators without EST Functionality (Model Nos. N2XXPAXN)

Ref.	Catalogue No.	Description	12	24	36	48	60	72	84	96	108	120
A	M12.NONEST.0001	12 Month Non EST Service Kit (Every 12 Months)	✓	✓	✓	✓	✓	✓	✓	✓	✓	✓
B	M24.PPM.0001	24 Month PPM Service Kit (Every 24 Months)		✓		✓		✓		✓		✓
C	M36.STD.0001	36 Month Standard Service Kit (Every 36 Months)			✓			✓			✓	
D	M60.STD.0001	60 Month Standard Service Kit (Every 60 Months)					✓					✓

Generators with EST Functionality (Model Nos. N2XXPAXY)

Ref.	Catalogue No.	Description	12	24	36	48	60	72	84	96	108	120
A	M12.EST.0001	12 Month EST Service Kit (Every 12 Months)	✓	✓	✓	✓	✓	✓	✓	✓	✓	✓
B	M24.PPM.0001	24 Month PPM Service Kit (Every 24 Months)		(x2)		(x2)		(x2)		(x2)		(x2)
C	M36.STD.0001	36 Month Standard Service Kit (Every 36 Months)			✓			✓			✓	
D	M60.STD.0001	60 Month Standard Service Kit (Every 60 Months)					✓					✓

5.3.2 Low Purity Generators (%)

Generators without EST Functionality (Model Nos. N2XXPBXN)

Ref.	Catalogue No.	Description	12	24	36	48	60	72	84	96	108	120
A	M12.NONEST.0001	12 Month Non EST Service Kit (Every 12 Months)	✓	✓	✓	✓	✓	✓	✓	✓	✓	✓
B	M24.PCT.0001	24 Month Percentage Service Kit (Every 24 Months)		✓		✓		✓		✓		✓
C	M36.STD.0001	36 Month Standard Service Kit (Every 36 Months)			✓			✓			✓	
D	M60.STD.0001	60 Month Standard Service Kit (Every 60 Months)					✓					✓

Generators with EST Functionality (Model Nos. N2XXPBXY)

Ref.	Catalogue No.	Description	12	24	36	48	60	72	84	96	108	120
A	M12.EST.0001	12 Month EST Service Kit (Every 12 Months)	✓	✓	✓	✓	✓	✓	✓	✓	✓	✓
B	M24.PCT.0001	24 Month Percentage Service Kit (Every 24 Months)		(x2)		(x2)		(x2)		(x2)		(x2)
C	M36.STD.0001	36 Month Standard Service Kit (Every 36 Months)			✓			✓			✓	
D	M60.STD.0001	60 Month Standard Service Kit (Every 60 Months)					✓					✓

5.3.3 Kit Contents



Catalogue No.	Description	Contents
M12.NONEST.0001	12 Month Non EST Service Kit (Every 12 Months)	Exhaust Silencer 025AR Dust filter element



Catalogue No.	Description	Contents
M12.EST.0001	12 Month EST Service Kit (Every 12 Months)	Exhaust Silencer 025AR Dust filter element In-line filter



Catalogue No.	Description	Contents
M24.PPM.0001	24 Month PPM Service Kit (Every 24 Months)	PPM Cell c/w wiring
M24.PCT.0001	24 Month Percentage Service Kit (Every 24 Months)	% Cell c/w wiring



Catalogue No.	Description	Contents
M36.STD.0001	36 Month Standard Service Kit (Every 36 Months)	8 Bank solenoid valve



Catalogue No.	Description	Contents
M60.STD.0001	60 Month Standard Service Kit (Every 60 Months)	40 x 25mm stroke cylinders (x6) Over moulded valve discs and guides (x6) 50 x 100mm stroke cylinders (x2) Valve discs (x2 sets) Valve bonnets (x2) Assorted o-rings Fixing screws

6 Troubleshooting

In the unlikely event that a problem occurs on the equipment, this troubleshooting guide can be used to identify the probable cause and remedy.



Troubleshooting should only be attempted by competent personnel. All major repair, and calibration work should be undertaken by a Parker domnick hunter trained, qualified and approved engineer.

Fault	Probable Cause	Remedy
Power Connected but LCD and status indicators not illuminated.	Fuse Blown	Replace Fuse
	Ribbon cable disconnected	Reconnect Ribbon cable
	Power disconnected	Reconnect Power
No / Low gas outlet pressure	Service Overdue	Service the generator
	Internal gas leak	Check and Rectify
	External gas leak	Check and Rectify
	Low inlet pressure	Ensure pressure meets required specification
High Oxygen concentration.	Defective Oxygen cell.	Replace.
	Leak in system piping.	Check and Rectify
Low inlet pressure	Compressor or ring main pressure low.	Check and Rectify
	Inlet valve not open	Check and Rectify
	Defect on pre-treatment package.	Refer to pre-treatment manual.
Excessive noise or vibration	Silencer loose or defective.	Check and Rectify
	Solenoid valve wear or coil loose.	Check and replace if required.
High outlet pressure.	Outlet regulator defective.	Reset or replace.

Fault Codes

Fault Codes	Notes	
C1	Pressure Start Inhibit	Low inlet pressure. Inhibits start.
P1	Inlet Pressure Fault	Low inlet pressure during cycling.
P2	Pressure Sensor Fault	Outlet pressure sensor communication error.
E1	Power Failure	
Y1	High oxygen alarm - outlet	
Y2	Oxygen sensor communication failure - outlet	Communication fault between O ₂ analyser and control board
Y3	Incorrect oxygen cell selected - outlet	
Y4	Oxygen reading high out of range - outlet	Occurs when O ₂ > 25% (% generators) / O ₂ > 1.05% (ppm generators)
Y5	Oxygen sensor fault - outlet	Contact Parker domnick hunter
Y6	Oxygen sensor communication failure - EST	
Y7	Incorrect oxygen cell selected - EST	
Y8	Oxygen sensor high out of range - EST	
Y9	Oxygen sensor fault - EST	
Y10	EST Board communication failure	
S1	Service due	

Declaration of Conformity

EN

Parker Hannifin Manufacturing Limited, domnick hunter Filtration and Separation
Dukesway, TVTE, Gateshead, Tyne & Wear, NE11 0PZ. UK

NitroSource N2 Nitrogen Gas Generator N2-20P - N2-80P

Directives

97/23/EC
2006/95/EC
2004/108/EC

Standards used

EN 61010-1 : 2010
EN 61326-1 : 2013
EN 61000-3-2 : 2006 + A2:2009
EN 61000-3-3 : 2013
Generally in accordance with ASMEVIII Div 1 : 2010 2011a
Addenda.

PED Assessment Route :

CAT III (N2-20P - N2-35P)
CAT IV (N2-45P - N2-80P)

EC Type-examination Certificate:

TBA

Notified body for PED:

Lloyds Register Verification
71 Fenchurch St. London
EC3M 4BS

Authorised Representative

Derek Bankier
Divisional Quality Manager
Parker Hannifin Manufacturing Limited, dhFNS

Declaration

I declare that as the authorised representative, the above information in relation to the supply / manufacture of this product, is in conformity with the standards and other related documents following the provisions of the above Directives.

Signature:



Date: 41969

Declaration Number: 00278/261114

Parker Worldwide

Europe, Middle East, Africa

AE – United Arab Emirates, Dubai

Tel: +971 4 8127100
parker.me@parker.com

AT – Austria, Wiener Neustadt

Tel: +43 (0)2622 23501-0
parker.austria@parker.com

AT – Eastern Europe, Wiener Neustadt

Tel: +43 (0)2622 23501 900
parker.easteurope@parker.com

AZ – Azerbaijan, Baku

Tel: +994 50 2233 458
parker.azerbaijan@parker.com

BE/LU – Belgium, Nivelles

Tel: +32 (0)67 280 900
parker.belgium@parker.com

BY – Belarus, Minsk

Tel: +375 17 209 9399
parker.belarus@parker.com

CH – Switzerland, Etoy

Tel: +41 (0)21 821 87 00
parker.switzerland@parker.com

CZ – Czech Republic, Klecany

Tel: +420 284 083 111
parker.czechrepublic@parker.com

DE – Germany, Kaarst

Tel: +49 (0)2131 4016 0
parker.germany@parker.com

DK – Denmark, Ballerup

Tel: +45 43 56 04 00
parker.denmark@parker.com

ES – Spain, Madrid

Tel: +34 902 330 001
parker.spain@parker.com

FI – Finland, Vantaa

Tel: +358 (0)20 753 2500
parker.finland@parker.com

FR – France, Contamine s/Arve

Tel: +33 (0)4 50 25 80 25
parker.france@parker.com

GR – Greece, Athens

Tel: +30 210 933 6450
parker.greece@parker.com

HU – Hungary, Budapest

Tel: +36 23 885 470
parker.hungary@parker.com

IE – Ireland, Dublin

Tel: +353 (0)1 466 6370
parker.ireland@parker.com

IT – Italy, Corsico (MI)

Tel: +39 02 45 19 21
parker.italy@parker.com

KZ – Kazakhstan, Almaty

Tel: +7 7272 505 800
parker.easteurope@parker.com

NL – The Netherlands, Oldenzaal

Tel: +31 (0)541 585 000
parker.nl@parker.com

NO – Norway, Asker

Tel: +47 66 75 34 00
parker.norway@parker.com

PL – Poland, Warsaw

Tel: +48 (0)22 573 24 00
parker.poland@parker.com

PT – Portugal, Leca da Palmeira

Tel: +351 22 999 7360
parker.portugal@parker.com

RO – Romania, Bucharest

Tel: +40 21 252 1382
parker.romania@parker.com

RU – Russia, Moscow

Tel: +7 495 645-2156
parker.russia@parker.com

SE – Sweden, Spånga

Tel: +46 (0)8 59 79 50 00
parker.sweden@parker.com

SK – Slovakia, Banská Bystrica

Tel: +421 484 162 252
parker.slovakia@parker.com

SL – Slovenia, Novo Mesto

Tel: +386 7 337 6650
parker.slovenia@parker.com

TR – Turkey, Istanbul

Tel: +90 216 4997081
parker.turkey@parker.com

UA – Ukraine, Kiev

Tel: +380 44 494 2731
parker.ukraine@parker.com

UK – United Kingdom, Warwick

Tel: +44 (0)1926 317 878
parker.uk@parker.com

ZA – South Africa, Kempton Park

Tel: +27 (0)11 961 0700
parker.southafrica@parker.com

North America

CA – Canada, Milton, Ontario

Tel: +1 905 693 3000

US – USA, Cleveland

Tel: +1 216 896 3000

Asia Pacific

AU – Australia, Castle Hill

Tel: +61 (0)2-9634 7777

CN – China, Shanghai

Tel: +86 21 2899 5000

HK – Hong Kong

Tel: +852 2428 8008

IN – India, Mumbai

Tel: +91 22 6513 7081-85

JP – Japan, Tokyo

Tel: +81 (0)3 6408 3901

KR – South Korea, Seoul

Tel: +82 2 559 0400

MY – Malaysia, Shah Alam

Tel: +60 3 7849 0800

NZ – New Zealand, Mt Wellington

Tel: +64 9 574 1744

SG – Singapore

Tel: +65 6887 6300

TH – Thailand, Bangkok

Tel: +662 186 7000-99

TW – Taiwan, Taipei

Tel: +886 2 2298 8987

South America

AR – Argentina, Buenos Aires

Tel: +54 3327 44 4129

BR – Brazil, Sao Jose dos Campos

Tel: +55 800 727 5374

CL – Chile, Santiago

Tel: +56 2 623 1216

MX – Mexico, Toluca

Tel: +52 72 2275 4200

European Product Information Centre

Free phone: 00 800 27 27 5374

(from AT, BE, CH, CZ, DE, DK, EE, ES, FI, FR, IE, IL, IS, IT, LU, MT, NL, NO, PL, PT, RU, SE, SK, UK, ZA)

Parker Hannifin Manufacturing Limited

domnick hunter Filtration and Separation Division
Dukesway, Team Valley Trading Est

Gateshead, Tyne and Wear

England NE11 0PZ

Tel: +44 (0) 191 402 9000

Fax: +44 (0) 191 482 6296

www.parker.com/dhfn